

Thank you for purchasing this TradeQuip product. Manufactured to a high standard this product will, if used according to these instructions and properly maintained, give you years of trouble free performance.



**IMPORTANT: PLEASE READ THESE INSTRUCTIONS CAREFULLY. NOTE THE SAFE OPERATIONAL REQUIREMENTS, WARNINGS & CAUTIONS. USE THE PRODUCT CORRECTLY AND WITH CARE FOR THE PURPOSE FOR WHICH IT IS INTENDED. FAILURE TO DO SO MAY CAUSE DAMAGE AND/OR PERSONAL INJURY, AND WILL INVALIDATE THE WARRANTY. PLEASE KEEP INSTRUCTIONS SAFE FOR FUTURE USE.**

## 1. SAFETY INSTRUCTIONS

- ✓ Only use this Parts Storage Bin Rack for the purpose for which it has been designed.
- ✗ Do not modify any component of this Parts Storage Bin Rack.
- ✓ When servicing, use only TradeQuip identical replacement parts. Use of any other parts will void the warranty.
- ✓ Safe Working Capacity 30kg.
- ✓ For your safety, ensure the brake is on.
- ✓ This product is intended for indoor use only.



## 2. CONTENTS & SPECIFICATIONS

- Safe Working Capacity: 30kg
- 12 Parts Bins 140x85x72mm (1kg each Load Capacity)
- 4 Parts Bins 210x125x123mm (1.5kg each Load Capacity)

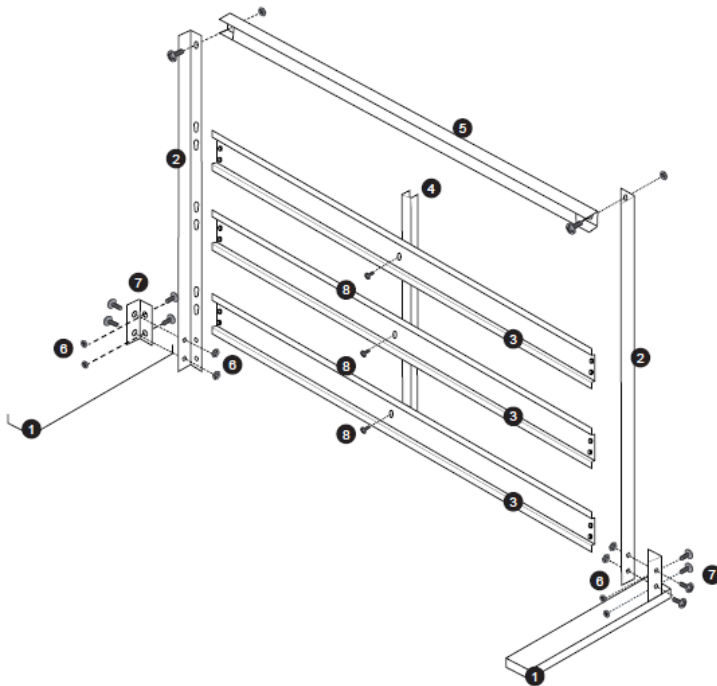

Part #	Description	QTY
1	Bottom Feet	2
2	L-Bar Frame Legs	2
3	Bin Support Brackets	3
4	Vertical Support Bracket	1
5	Magnetic Tool Holder	1
6	Large Nuts	10
7	Large Bolts	10
8	Small Bolts	3

## 3. ASSEMBLY INSTRUCTIONS

1. Use four sets of the Large Bolts (7) and Large Nuts (6) to attach the Bottom Feet (1) to the L-Bar Frame Legs (2). **Note:** ensure the Frame Legs sit inside the L Bracket.
2. Attach the Bin Support Brackets (3) to the Frame Legs (2) by aligning the eyelets and gently pushing down.
3. Fasten the Vertical support Bracket (4) to the Bin support Brackets (3) using the Small Bolts (8) and tighten to secure.
4. Align the magnetic tool Holder (5) with the top holes of the Frame Legs and secure into place using the remaining Bolts & Nuts.
5. Once assembled ensure all bolts and Nuts are tightened and secure.
6. Dispose of all packaging material responsibly.