

WORKSHOP EQUIPMENT

Established 1984 - Trusted by
Australia's trade for more than
40 YEARS

**MADE FOR THE
TRADE**

PRICED PRODUCT GUIDE

VALID THROUGH TO SEPTEMBER 2024

TQB Trusted by Australia's Trade for...

TQB Brands Pty Ltd



YEARS

Thank You Australia!

TRANSMISSION LIFTER PASSENGER VEHICLES

2059T **TRADEQUIP**
The trusted brand in equipment

Safe working capacity: RWD/FWD GVM <2,000KG
Rated capacity: 500kg
Working height: 820-1768mm
Forward tilt: 9° Rearward tilt: 17°
Weight: 52kg



Excludes GST
\$799
Inc. GST \$878.90



TRANSMISSION LIFTER PASSENGER VEHICLES

2022T **TRADEQUIP**
The trusted brand in equipment

Safe working capacity: RWD/FWD/AWD GVM <2,300KG
Rated capacity: 500kg
Working height: 895-1875mm
Cradle size: 240 x 340mm
Tilt Angle: Left 7° Right 15°
Weight: 73kg

FEATURES

High-grade steel for quality and durability. Lead-free paint prevents rust and is oil, grease and dirt-resistant for easy cleanup. Universal mounting cradle provides wide fore & aft tilt. High quality large diam. hydraulic steel cylinder unit. Piston-ram treated & polished to extend service life.



TRANSMISSION LIFTER PASSENGER VEHICLES

2052 **TRADEQUIP**
The trusted brand in equipment

Safe working capacity: RWD/FWD/AWD GVM <2,500KG
Rated capacity: 500kg
Working height: 855-1760mm
Cradle size: 276 x 360mm
2 Stage lift
4 way tilting working head
Tilt: Fwd 15° Rwd 7° Lat 7°
Base: 690 x 780mm
Weight: 61kg

FEATURES

High-grade steel for quality and durability. Lead-free paint prevents rust and is oil, grease and dirt-resistant for easy cleanup. Universal mounting cradle provides wide fore & aft tilt. High quality large diam. hydraulic steel cylinder unit. Piston-ram treated & polished to extend service life.



TRANSMISSION LIFTER SUV / 4X4 & LIGHT COMMERCIAL

2063T **TRADEQUIP**
The trusted brand in equipment

Safe working capacity: RWD/FWD/AWD/4X4 GVM <3,200KG
Rated capacity: 1,000kg
Working height: 940-1920mm
Lift platform size: 280 x 280mm
Tilt: Fwd 15° Tilt Rwd 10°
Tilt: Side 9° Tilt Side 11°
Weight: 82kg

FEATURES

High-grade steel for quality and durability. Lead-free paint prevents rust & is oil, grease and dirt-resistant for easy cleanup. Universal mounting cradle gives wide fore & aft tilt. High quality large diam. hydraulic steel cylinder. Polished & treated Piston-ram extends service life.



WARNING INTENDED USE: Removal & Installation of Transmissions
NOT INTENDED FOR: Supporting Loads i.e. Fuel Tanks, Suspension Work, BullBar Installations

TRANSMISSION LIFTER PASSENGER VEHICLES

PROTL500

Safe working capacity:
RWD/FWD/AWD GVM <2,500KG
Rated capacity: 500kg
Working height: 940-1940mm
Ram travel 1st stage: 490mm
Ram travel 2nd stage: 510mm
Tilt: Fwd 9° Rwd 28° Left 9° Right 28°
Base: 610 x 740mm
Weight: 65kg

LATEST APPLIED TECHNOLOGIES
TQ Pro
Trusted by serious professionals

Professional Reputable Outstanding



FEATURES

Piston-ram is treated and polished to minimise wear and extend service life.
Premium quality (doubled) O rings with anti-dust ring.
Rapid lift without load.
Slow descent with load.
Overload safety valve.
Aviation grade hydraulic fluid.

Foot operated quicklift pump



Maximum height: 1940mm

Wide wheel stability

Excludes GST
\$1299
Inc. GST \$1428.90



TRANSMISSION LIFTER SUV 4X4 & LIGHT COMMERCIAL

2057T

TRADEQUIP
The trusted brand in equipment

MADE FOR THE TRADE

Safe working capacity:
RWD/FWD/AWD/4X4 GVM <3,500KG
Rated capacity: 1,000kg
Working height: 205-725mm
Cradle size: 340 x 200mm

Tilt: Fwd 70° Rwd 15°
Cradle lateral adjustment: 90mm
Chassis: 850L x 490W x 305Hmm
Weight: 54kg

FEATURES

Adjustable head (forward & backward).
Lateral cradle adjustment.
Hydraulic system overload protection.
Four (4) swivel castors allow easy movement and positioning of transmission jack.
Rugged heavy duty steel wheels with full swivel ball bearing castors.
User-friendly 360° rotating pump handle.

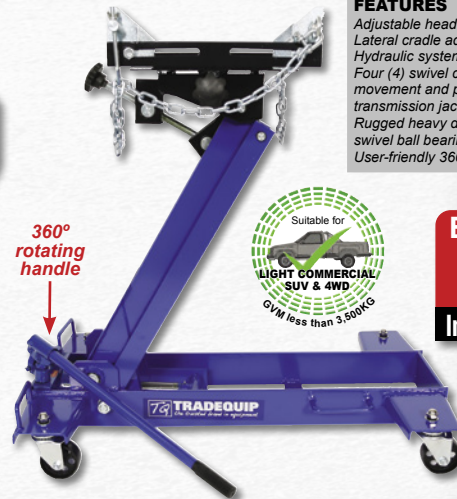

360° rotating handle



Excludes GST
\$819
Inc. GST \$900.90

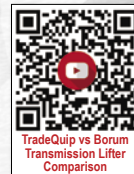

TRANSMISSION LIFTER SUV 4X4 & LIGHT COMMERCIAL

PROTL1000

Safe working capacity:
RWD/FWD/AWD/4X4 GVM <3,500KG
Rated capacity: 1,000kg
Working height: 940-1940mm
Ram travel 1st stage: 490mm
Ram travel 2nd stage: 510mm
Tilt: Fwd 9° Rwd 28° Left 9° Right 28°
Base: 610 x 740mm
Weight: 76.5kg

LATEST APPLIED TECHNOLOGIES
TQ Pro
Trusted by serious professionals

Professional Reputable Outstanding



FEATURES

Piston-ram is treated and polished to minimise wear and extend service life.
Premium quality (doubled) O rings with anti-dust ring.
Rapid lift without load.
Slow descent with load.
Overload safety valve.
Aviation grade hydraulic fluid.

Foot-operated quicklift pump



4 way tilt action

Maximum height: 1940mm

Wide wheel stability

Excludes GST
\$1835
Inc. GST \$2018.50

TRANSMISSION LIFTER COMMERCIAL VEHICLES

BHDTJ2

BORUM
INDUSTRIAL WORKSHOP EQUIPMENT

Safe working capacity: 2,000kg
Working height: 210-900mm
Cradle size: min. 385-470mm
Cradle size: max. 570-470mm
Adjustable tilt cradle
Cradle forward tilt: 30°
Cradle backward tilt: 30°
Swivel castors: 100mm
Chassis: 1160L x 685Wmm
Weight: 130kg

FEATURES

The adjustable cradle can be tilted forward or backward for optimum alignment of transmission bolt patterns and pins.
Hydraulic system is protected from overload damage.
Safety load-restraint for raising & lowering safety.
Rugged steel wheels & full swivel ball bearing castors.
User-friendly 360° rotating pumping handle.

INDUSTRIAL QUALITY

Excludes GST
\$2111
Inc. GST \$2322.10



900mm maximum lift height



Large adjustable cradle size

360° rotating handle

WARNING INTENDED USE: Removal & Installation of Transmissions
NOT INTENDED FOR: Supporting Loads i.e. Fuel Tanks, Suspension Work, BullBar Installations

UNDERHOIST AUXILIARY STAND 680KG

1198T **TRADEQUIP**
The trusted brand in equipment

Safe working capacity: 680kg
Height: 1370-2045mm
Base diameter: 300mm
Weight: 16.5kg



FEATURES

Fast and safe technology for professional mechanics.
Heavy gauge steel frame prevents distortion or twisting.
Provides partial support for components - NOT designed to support the vehicle.
Foot pedal allows easy load movement and hand free operation.
Quick action adjustable height mechanism.
Sold individually recommended only to be used individually.

Excludes GST
\$195
Inc. GST \$214.50

Hands free foot pedal operation



680kg Capacity



AUXILIARY LIFTER 500KG

2058T **TRADEQUIP**
The trusted brand in equipment

Rated capacity: 500kg
Working height: 1175-1985 mm
Lifting platform size:
A: 362 x 362mm
B: Φ 107.5mm



Includes Cradle and Lift Pad



500kg Capacity

FEATURES

This TradeQuip "Made for the Trade" 500kg Auxiliary Lifter is the perfect underhoist aid during removal and installation of small components. It features a mounting cradle and lift pad and a manually operated hydraulic system with smooth hydraulic lift and descent. The hydraulic system also includes a bypass system to prevent over extension and accidental overloading.

NOT INTENDED FOR SUPPORTING LOADS AND NOT INTENDED AS STAND ALONE TRANSMISSION LIFTER



Excludes GST
\$489
Inc. GST \$537.90



TOO NEW TO PHOTOGRAPH. VISIT WWW.TQBBrands.COM.AU FOR UPDATED IMAGES AND MORE SPECS.

AUXILIARY LIFTER KIT 500KG

2068T **TRADEQUIP**
The trusted brand in equipment

Rated capacity: 500kg
Working height: 1175-1985 mm
Lifting platform size:
A: 362 x 362mm
B: Φ 107.5mm
C: 812 X 352mm



Includes Cradle, Lift Pad & Fuel Tank Adaptor



500kg Capacity

FEATURES

This TradeQuip "Made for the Trade" 500kg Auxiliary Lifter is the perfect underhoist aid during removal and installation of small components. It features a mounting cradle and lift pad and a manually operated hydraulic system with smooth hydraulic lift and descent. The hydraulic system also includes a bypass system to prevent over extension and accidental overloading.

NOT INTENDED FOR SUPPORTING LOADS AND NOT INTENDED AS STAND ALONE TRANSMISSION LIFTER

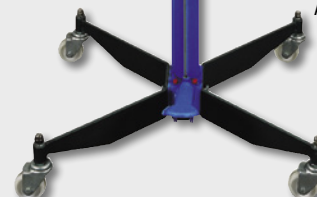

Excludes GST
\$679
Inc. GST \$746.90

Top Tips

Product information



Scan code to go to our Top Tips Transmission Lifter Guide and learn how to extend the life of your TQB Brands equipment



Visit our webpage www.tqbbrands.com.au for instructional & pre-start videos.

*Additional Freight Rates may apply

SCISSOR LIFTERS

SCISSOR LIFT WORKSHOP TROLLEY 300KG

6008T **TRADEQUIP**
The trusted brand in equipment

Safe working capacity: 300kg
Working height: 350mm-1285mm
Table size: 820L x 520Wmm

Excludes GST

\$1049

Inc. GST \$1153.90

**DOUBLE
SCISSOR
HIGH
LIFT**

**MADE FOR THE
TRADE**

FEATURES

Hands free foot-operated hydraulic pedal.
Heavy duty oil-resistant nonslip mat.
Powder coated all steel construction.
Perfect for moving parts to vehicles.



**300kg
Capacity**



SCISSOR LIFT WORKSHOP TROLLEY 500KG

6009T **TRADEQUIP**
The trusted brand in equipment

Safe working capacity: 500kg
Working height: 265mm-865mm
Table size: 820L x 520Wmm

Excludes GST

\$829

Inc. GST \$911.90

NEW

**MADE FOR THE
TRADE**

FEATURES

Hands free foot-operated pedal.
Quick release hand lever for easy, controlled release.
Heavy duty oil-resistant nonslip mat.
Powder coated all steel construction.
Perfect for moving parts to vehicles.



**500kg
Capacity**



SCISSOR LIFT WORKSHOP TROLLEY 225KG

6010T **TRADEQUIP**
The trusted brand in equipment

Safe working capacity: 225kg
Working height: 225mm-710mm
Table size: 708L x 450Wmm

Excludes GST

\$449

Inc. GST \$493.90

**225kg
Capacity**

**MADE FOR THE
TRADE**

FEATURES

Hands free foot-operated pedal.
Quick release hand lever for easy, controlled release.
Heavy duty oil-resistant nonslip mat.
Powder coated all steel construction.
Perfect for moving parts to vehicles.



TOO NEW TO PHOTOGRAPH. VISIT WWW.TQBBRANDS.COM.AU FOR UPDATED IMAGES AND MORE SPECS.

SCISSOR LIFT WORKSHOP TROLLEY 500KG

6007T **TRADEQUIP**
The trusted brand in equipment

Safe working capacity: 500kg
Working height: 440-1575mm
Table size: 1010L x 520Wmm
Wheel diameter: 150mm
Dimensions: 1130L x 520W x 1260Hmm

FEATURES

Double Scissor High Lift.
Foot-operated hydraulic pedal keeps your hands free.
Quick release hand lever for easy, controlled hydraulic release.
2 locking heavy duty swivel castors.
All steel construction.
Powder coated for extra protection.
Perfect for moving heavy parts to and from the vehicle.

**MADE FOR THE
TRADE**



**DOUBLE
SCISSOR
HIGH
LIFT**

**500kg
Capacity**

Excludes GST

\$1629

Inc. GST \$1791.90

SCISSOR LIFT WORKSHOP TROLLEY 450KG

6003T **TRADEQUIP**
The trusted brand in equipment

Safe working capacity: 450kg
Working height: 280-875mm
Table size: 500 x 810mm
Wheel Diameter: 125mm
Dimensions: 1140L x 515W x 995Hmm

FEATURES

Hands free foot-operated hydraulic pedal.
Quick release hand lever.
Heavy duty oil-resistant nonslip mat.
Powder coated all steel construction.
Perfect for moving heavy parts to vehicles.

**450kg
Capacity**



Excludes GST

\$898

Inc. GST \$987.80

**MADE FOR THE
TRADE**

**FOLDABLE
HANDLE**

GARAGE JACK 3,000KG LOW PROFILE

2906T **TRADEQUIP**
The trusted brand in equipment

Working load limit: 3,000kg
Height: 118 - 488mm
Handle length: 1400mm
Front wheels: 90mm dia 40mm width
Rear castors: 60mm dia 25mm width
Saddle diameter: 115mm
Dimensions: 670L x 380W x 170Hmm
Weight: 43kg

FEATURES

Low profile and deep reach.
Heavy gauge steel construction.
1400mm long handle for deeper reach.
Quick Lift Dual Pump technology.
Internal bypass valve overload protection.
Lead-free paint finish to ensure a long-lasting finish and prevent rust.
Paint is oil, grease and dirt-resistant.
Protective foam handle cover prevents vehicle damage.

HIGH LIFT - LOW PROFILE AND DEEP REACH

118mm min. lift height

3000kg Capacity

Protective foam handle cover

MADE FOR THE TRADE

Dual pump lift technology

HEAVY GAUGE STEEL

488mm max. lift height

MECHANICS CREEPER CADDY

TQTC1220 **TRADEQUIP**
The trusted brand in equipment

Safe working capacity: 25kg
Tray depth: 43mm (inner)
Swivel castors: 4x 50D x 16Wmm
435L x 400W x 120Hmm
(castor included)

MADE FOR THE TRADE

FEATURES

Easy to clean finish that is oil and solvent resistant and won't rust.
4 smooth-rolling swivel castors.
Impact resistant polymer plastic.
Built-in parts/tool storage compartments.

25kg Capacity

Excludes GST \$45

Incl. GST \$49.50

CAR AND 4WD JACK STANDS

TRADEQUIP
The trusted brand in equipment

FEATURES

Constructed of high-grade steel & built to exacting standards for quality & durability.
Lead-free paint finish is oil, grease and dirt-resistant for easy cleanup.
Quick action adjustable height mechanism.
Double-lock safety pin design for extra safety and security. (1128T & 1148T).
Welded steel frame & cast iron support.
Adjustable height.
Reinforced shaft for added strength stability.
Sold in pairs and only recommended to be used in pairs.

MADE FOR THE TRADE



| Code | 1128T | 1148T | 1162T |
|-------------|-----------|-----------|-----------|
| Load limit | 2,000kg | 4,000kg | 8,000kg |
| Min. Height | 285-428mm | 395-605mm | 468-715mm |
| Base Area | 206x186mm | 287x252mm | 324x294mm |
| Excl. GST | \$99 | \$174 | \$295 |
| Incl. GST | \$108.90 | \$191.40 | \$324.50 |

RATCHETING POSITIONING JACKS

1054T **TRADEQUIP**
The trusted brand in equipment

Safe working capacity: 680kg each
Max. distance between rollers: 710mm
Min. distance between rollers: 340mm
Suits tyres up to: 280mm (W)
Swivel castors: 100mm

MADE FOR THE TRADE

Heavy duty nylon swivel castors

Easy foot pedal lift

FEATURES

Steel construction with metal rollers.
Heavy duty nylon swivel castors.
Easy foot-pedal lifting design.
2 jacks permit full 180° vehicle pivot.
4 jacks place vehicle on a 360° rolling platform.
Lead-free paint finish helps prevent rust and is oil, grease and dirt-resistant for easy cleanup.
Quick action adjustable height mechanism.
Sold & recommended only to be used in pairs.

Excludes GST \$469

Incl. GST \$515.90

pair

MECHANICS CREEPER 130KG

1023T **TRADEQUIP**
The trusted brand in equipment

Safe working capacity: 130kg
1010L x 475W x 115Hmm

MADE FOR THE TRADE

Excludes GST \$88

Incl. GST \$96.80



FEATURES

The creeper body is manufactured to "Made for the Trade" quality using a high-impact polymer material that resists impacts, won't rust and is easy to clean.
Comfortable padded headrest and load capacity of up to 130kg, this low-profile creeper is one of the lightest and most durable available.

Convenient tool trays on each side

from

Excludes GST \$99

Incl. GST \$108.90

Quick Action Adjustable Height



4000kg Capacity

8000kg Capacity

2000kg Capacity

WHEEL TYRE LIFTER

1055T  **TRADEQUIP**
The trusted brand in equipment

Safe working capacity: 50kg
 Rollers moving distance: 125mm
 Roller diameter & length: (D) 76.2 x 240mm
 Rollers push force: <4kg based on 50kg load
 Lifting handle force: 1kg based on 50kg load
 Overall height: 1380mm
 Overall base dimensions: 725W x 872D mm
 Roller working range: 100mm to 1060mm
 Front castors: 2(D) 75 x 24mm
 Rear castor - Locking: 2(D) 75 x 24mm
 Weight: 51.25kg

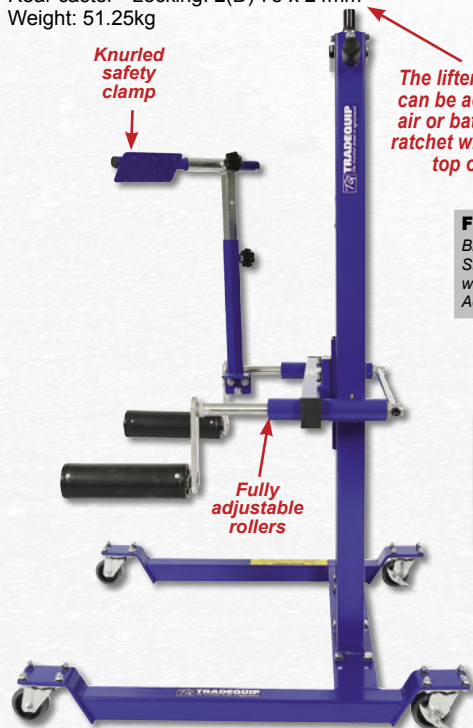

Knurled safety clamp

The lifters drive screw can be activated by an air or battery-operated ratchet wrench from the top of the unit.

Fully adjustable rollers

TRULY MOBILE...
NO ADDITIONAL AIR LINE
OR CHARGING CABLES
NEEDED

MADE FOR THE TRADE

FEATURES

Braked Swivel Castor.
 Sturdy Frame to safely transport wheel around workshop.
 Adjustable Safety Brace.

Excludes GST
\$1059
 Inc. GST \$1164.90



Nut & bolt storage tray

1380mm

50kg Capacity

Braked swivel castors

For the lifting, lowering, supporting & transporting of tyre & rim assemblies up to 50kgs & 300mm wide.

WHEEL DOLLY SINGLE 250KG

B250WH  **BORUM**
INDUSTRIAL WORKSHOP EQUIPMENT

Safe working capacity: 250kg
 Maximum depth: 305mm
 Overall height: 1000mm
 Weight: 14kg

FEATURES

Adjustable arms.
 Equipped with rollers for easy positioning.
 Stop rollers on the rear side.
 Ergonomic handle with rounded & soft safety grip.



NEW

INDUSTRIAL QUALITY

Excludes GST
\$399
 Inc. GST \$438.90

This BORUM WHEEL DOLLY is a sturdy & handy transport aid for various types of wheels (trucks, vans, utes and cars). This versatile and easy to operate piece of equipment features adjustable arms. Equipped with two wheels and an ergonomic handle, the units manoeuvrability is not hampered by the size of the wheel.



250kg Capacity

SUPPORT STAND 10,000KG

10TSS **BORUM**
INDUSTRIAL WORKSHOP EQUIPMENT

Safe working capacity: 10,000kg
Working height: 720-1190mm
Adjustable pin heights: 10
Saddle dimensions: 150x80mm
Base: 406 x 556mm
Weight: 23.5kg

Excludes GST
\$399
Inc. GST \$438.90

INDUSTRIAL QUALITY

10,000kg Capacity

Max. height 1190mm

FEATURES
Stable 4 legged stability.
Lead-free paint is oil, grease and dirt-resistant for easy cleanup.
High strength locking pin & controlled pin holes for easy height adjustments.
Turned post slide for easy quick adjustments.

*10TSS/10TSSSHORT SOLD INDIVIDUALLY

SUPPORT STAND 10,000KG SHORT

10TSSSHORT **BORUM**
INDUSTRIAL WORKSHOP EQUIPMENT

Safe working capacity: 10,000kg
Working height: 480-780mm
Adjustable pin heights: 6
Saddle dimensions: 150x80mm
Base: 310 x 310mm
Weight: 18kg

Excludes GST
\$359
Inc. GST \$394.90

JUMBO SPANNER SET 10 PCE IMPERIAL

B10PJSI **BORUM**
INDUSTRIAL WORKSHOP EQUIPMENT

10 Imperial Sizes:
1 5/16", 1 3/8", 1 7/16", 1 1/2", 1 5/8",
1 11/16", 1 3/4", 1 13/16", 1 7/8" 2"
Wallet rolled out: 830 x 690 x 30mm
Wallet rolled up: 150 x 690 x 130mm
Weight: 14kg

Excludes GST
\$255
Inc. GST \$280.50

INDUSTRIAL QUALITY



JUMBO SPANNER SET 10 PCE METRIC

B10PJS **BORUM**
INDUSTRIAL WORKSHOP EQUIPMENT

10 Metric Sizes:
34mm, 36mm, 38mm, 41mm, 42mm,
44mm, 45mm, 46mm, 48mm & 50mm
Wallet rolled out: 830 x 690 x 30mm
Wallet rolled up: 150 x 690 x 130mm
Weight: 14kg

Excludes GST
\$255
Inc. GST \$280.50



AUXILIARY STAND 7,000KG

BAUXST **BORUM**
INDUSTRIAL WORKSHOP EQUIPMENT

Safe working capacity: 7,000kg
Working height: 1295-1905mm
Adjustable pin heights: 8 (75mm increments)
Base: 300x300x300mm
Weight: 65kg

Excludes GST
\$1499
Inc. GST \$1648.90

7,000kg Capacity

FEATURES
Heavy duty design and support bracing system to sustain heavy vehicle loads.
Manufactured from high-grade steel and built to exacting standards for quality and durability.
Fitted with spring loaded castor wheels to ensure easy movement around the workshop.
Fitted with spring loaded support beam.
Lead-free paint finish is applied after a thorough chemical wash to ensure a long-lasting finish and to help prevent rust.
Paint is oil, grease and dirt-resistant for easy cleanup.
High strength locking pin.
Controlled pin holes for easy height adjustments.
Turned post slide for easy quick adjustments.

Max. height 1905mm



3 saddle options:
90mm, 120mm, up to 150mmØ



Spring loaded castor wheels

INDUSTRIAL QUALITY



TRUCK JACK STANDS SOLD INDIVIDUALLY

BORUM
INDUSTRIAL WORKSHOP EQUIPMENT

| Code | 15TJSSSHORT | 15TJS |
|------------------|-----------------|-----------------|
| Load limit | 15,000kg | 15,000kg |
| Height | 446 - 631mm | 645-1077mm |
| Base Area | 300x300mm | 460x460mm |
| Excl. GST | \$425 | \$519 |
| Incl. GST | \$467.50 | \$570.90 |

| Code | 25TJSSSHORT | 25TJS |
|------------------|-----------------|-----------------|
| Load limit | 25,000kg | 25,000kg |
| Height | 415 - 539mm | 680-968mm |
| Base Area | 300x300mm | 460x460mm |
| Excl. GST | \$529 | \$599 |
| Incl. GST | \$581.90 | \$658.90 |

FEATURES
Manufactured from high-grade steel and built to exacting standards for quality and durability.
Lead-free paint finish is oil, grease and dirt-resistant for easy cleanup.
High strength locking pin.
Controlled pin holes for easy height adjustments.
Turned post slide for easy quick adjustments.
Heavy-gauge steel Gusseted uprights prevent distortion or twisting.
Rugged base provides plenty of stability.
Conveniently located carry handle.
Sold individually. (not in pairs)

INDUSTRIAL QUALITY

from

Excludes GST
\$425
Inc. GST \$467.50



AIR ACTUATED TRUCK JACK 22,000KG

B2003T **BORUM**
INDUSTRIAL WORKSHOP EQUIPMENT

Safe working capacity: 22,000kg
Lift range: 210-525mm
Hydraulic lift: 120mm
Adjustable height: 80mm
Chassis: 500L x 215H x 320Wmm
Adaptors: 19, 55, 100mm
Handle length: 1065mm

INDUSTRIAL QUALITY

LIFTS
22,000KG

Includes Height Adaptors

Excludes GST
\$1029
Inc. GST \$1132.90



FEATURES
Solid heavy duty construction.
Advanced technology sealing rings.
Fast motion super duty air pump.
Temperature-resistant hydraulic oil.
Treated and polished piston and ram.
Built-in bypass hydraulic safety overload system.
Compact design easily fits dual tandem axles.
Convenient & efficient height adaptors.
3-position pumping handle.
High quality lead-free paint is oil, grease and dirt-resistant finish for easy cleanup.

AIR JACK/SUPPORT STAND 10,000KG

BSJ10T **BORUM**
INDUSTRIAL WORKSHOP EQUIPMENT

Safe working capacity: 10,000kg
Maximum height: 1298mm
Minimum height: 444mm
Hydraulic lift: 292mm
Base diameter: 339mm
Rated air pressure capacity: 200psi
Weight: 91kg

FEATURES

The BORUM Industrial AIR JACK/SUPPORT STAND 10,000KG is a reinforced pin style jack and stand with industrial quality design and support bracing system to sustain heavy loads up to 10,000kg. Adjusts to match the job with a 444mm minimum height, 292mm of hydraulic lift and up to 1298mm maximum height using the extension tube!! Featuring Heavy-Duty Industrial design, this tough air jack/support stand is ideal for truck, bus, farm, earthmoving equipment and fleet vehicle maintenance workshop use.



NEW

TOO NEW TO PHOTOGRAPH. VISIT WWW.TQBBRANDS.COM.AU FOR UPDATED IMAGES AND MORE SPECS.

Excludes GST
\$1349
Inc. GST \$1483.90

INDUSTRIAL QUALITY

AIR ACTUATED TRUCK JACK 22,000KG

2004T **TRADEQUIP**
the trusted brand in equipment

Safe working capacity: 22,000kg
Lift range: 210-525mm
Hydraulic lift: 120mm
Adjustable height: 80mm
Chassis: 500L x 215H x 320Wmm
Adaptors: 19, 55, 100mm
Handle length: 1065mm

MADE FOR THE TRADE



Includes Height Adaptors

LIFTS
22,000KG

Excludes GST
\$819
Inc. GST \$900.90

FEATURES
Trade quality rugged steel construction.
Wear-resistant quality sealing O-rings.
Strong hydraulic pump.
Temperature-resistant hydraulic oil.
Treated and polished piston and Quick lift ram.
Built-in bypass hydraulic safety overload system.
Compact design easily fits dual tandem axles.
Convenient & efficient height adaptors.
3-position pumping handle.
High quality lead-free paint is oil, grease and dirt-resistant finish for easy cleanup.



PORTABLE TRUCK RAMPS

BTR20TP **BORUM**
INDUSTRIAL WORKSHOP EQUIPMENT

Safe working load: 20,000kg per pair
Frame: 1160L x 463W x 242Hmm
Max. tyre width: 393mm

INDUSTRIAL QUALITY

SOLD IN PAIRS
pair

Excludes GST
\$1710
Inc. GST \$1881.00

Suitable for Buses and Trucks



FEATURES

Long retractable T-handle for easy positioning.
"NON-SKID BASE" - 4 ply pads of rubber grips are bolted and glued to the 6mm steel floor plates and they will not skid ahead of the wheels.
Replaces need for a pit or hoist, and at a fraction of the cost and floor space.

AIR ACTUATED TRUCK JACK 20,000KG

PROTRJA20T

Safe working capacity: 20,000kg
Working height: 215-541mm
Hydraulic Lift: 141mm
Adjustable screw: 85mm
Adaptors: 20, 50, 100mm
Handle length: 1335mm
Operating air pressure: 145-175psi
Chassis: 520L x 215H x 258Wmm

LATEST APPLIED TECHNOLOGIES
TQ PRO

Trusted by serious professionals

Professional Reputable Outstanding

SELF-RETURNING LOWERING & LIFTING SWITCH

LIFTS
20,000KG

Excludes GST
\$1349
Inc. GST \$1483.90

FEATURES
Double sealing using XTP industry sealing.
Telescopic air actuation lift (air-hydraulic pump).
Long T-handle lets you easily position your jack under vehicle.
Self-returning lowering and lifting switch.
Internal and external cylinders hard chromed.
High manoeuvrability & deep reach.
3 extension adaptors/saddle plates.



TRUCK WHEEL LIFTER

BTWD750 **BORUM**
INDUSTRIAL WORKSHOP EQUIPMENT

Safe working capacity: 750kg
Lift arm spread: 533-635mm
Lifting range: 60-275mm
Tilt range: -2.5 to 10 degrees
787L x 1092W x 895H mm

Excludes GST
\$969
Inc. GST \$1065.90

INDUSTRIAL QUALITY

750kg Capacity

Suitable for Buses and Trucks



AIR ACTUATED JACK 2 STAGE 15,000/30,000KG

BTJ1530TA **BORUM**
INDUSTRIAL WORKSHOP EQUIPMENT

1st stage: 30,000kg safe working capacity
2nd stage: 15,000kg safe working capacity
First stage hydraulic lift: 73mm
Second stage hydraulic lift: 66mm
Operating air pressure: 145-175psi
Height: 150-409mm
Adaptors: 45 and 75mm
Handle length: 1300mm
Chassis: 480 x 290 x 150mm



FEATURES

Double sealing function using XTP industry sealing.
Telescopic air actuation lift (air-hydraulic pump).
Long T-handle lets you easily position your jack under vehicle.
Self-returning lower & lift switch.
Internal and external cylinders hard chromed.
High manoeuvrability & deep reach under vehicles.
2 extension adaptors/saddle plates.
Large rubber wheels.

**LIFTS
30,000KG**

**INDUSTRIAL
QUALITY**

Excludes GST
\$2479

Inc. GST \$2726.90

Includes
Height
Adaptors



AIR ACTUATED TRUCK JACK 35,000KG

BTJ35TA **BORUM**
INDUSTRIAL WORKSHOP EQUIPMENT

Safe working capacity: 35,000kg
Lift range: 255-633mm
Hydraulic lift: 155mm
Adjustable height: 123mm
Adaptors: 21, 61, 100mm
Handle length: 1110mm
Operating air pressure: 110-125psi
Chassis: 555L x 255H x 295Wmm

**INDUSTRIAL
QUALITY**

FEATURES

Pro quality rugged steel construction.
Wear-resistant quality sealing O-rings.
Strong hydraulic pump & 3-position handle.
Temperature-resistant hydraulic oil.
Treated and polished piston and ram.
Built-in bypass hydraulic safety overload.
Compact design and Quick Lift ram.
Convenient & efficient height adaptors.
High quality lead-free paint.

Excludes GST
\$1169
Inc. GST \$1285.90

Includes
Height
Adaptors

**LIFTS
35,000KG**



AIR ACTUATED TRUCK JACK 50,000KG

BTJ50TA **BORUM**
INDUSTRIAL WORKSHOP EQUIPMENT

Safe working capacity: 50,000kg
Lift range: 287-650mm
Hydraulic lift: 153mm
Adjustable screw: 110mm
Adaptors: 20, 60, 100mm
Handle length: 1230mm
Operating air pressure: 110-125psi
Chassis: 525L x 288H x 325Wmm

**INDUSTRIAL
QUALITY**

FEATURES

Pro quality rugged steel construction.
Wear-resistant quality sealing O-rings.
Strong hydraulic pump & 3-position handle.
Temperature-resistant hydraulic oil.
Treated and polished piston and ram.
Built-in bypass hydraulic safety overload.
Compact design and Quick Lift ram.
Convenient & efficient height adaptors.
High quality lead-free paint.

Excludes GST
\$1619
Inc. GST \$1780.90

Includes
Height
Adaptors

**LIFTS
50,000KG**



AIR ACTUATED TRUCK JACK 60,000KG

BTJ60TA **BORUM**
INDUSTRIAL WORKSHOP EQUIPMENT

Safe working capacity: 60,000kg
Lift range: 420-1031mm
Hydraulic lift: 311mm
Adaptors: 100 & 200mm
Handle length: 1290mm
Operating air pressure: 145-175psi
Chassis: 910L x 420H x 300Wmm

**INDUSTRIAL
QUALITY**

**SUITS
HIGH
AXLES**

FEATURES

Double sealing function using XTP industry sealing.
Telescopic air actuation lift.
Self-returning lowering and lifting switch.
Internal & external cylinders hard chromed
Long T-handle for high manoeuvrability & deep reach under vehicles.
Designed for extremely high axles.

Excludes GST
\$4999
Inc. GST \$5498.90

Includes
Height
Adaptors

**LIFTS
60,000KG**



TRUCK WHEEL NUT WRENCH TORQUE MULTIPLIER

8033 **TRADEQUIP**
the trusted brand in equipment

1" Drive hand winder operated
Trans-speed ratio: 1:56
27mm, 32mm, 33mm, 41mm
wheel nut sockets
Torque output: 4800Nm

INDIVIDUAL
SOCKETS
AVAILABLE



**MADE FOR THE
TRADE**



Suitable
for Buses
and Trucks

Excludes GST
\$169
Inc. GST \$185.90

*Additional Freight Rates may apply

TRUCK JACKS

AIR ACTUATED 2 STAGE TRUCK JACK 10,000/25,000KG

BTJ1025TA **BORUM**
INDUSTRIAL WORKSHOP EQUIPMENT

Stage 1: 25,000kg safe working capacity
Stage 2: 10,000kg safe working capacity
Lift range: 185-497mm
Hydraulic lift: Stage1: 97mm, Stage2: 95mm
Adaptors: 45, 75mm
Handle length: 1380mm
Operating air pressure: 145-175psi
Chassis: 770L x 282H x 185Wmm

LIFTS
25,000KG

INDUSTRIAL QUALITY

Includes
Height
Adaptors

Excludes GST
\$3182
Inc. GST \$3500.20

DEEP REACH

FEATURES

Double sealing function - XTP industry sealing.
Telescopic air actuation lift.
Self-returning lowering and lifting switch.
Internal & external cylinders hard chromed
Long T-handle for high manoeuvrability & deep reach under vehicles.



AIR ACTUATED 3 STAGE TRUCK JACK 20,000/40,000/60,000KG

BTJ204060TA **BORUM**
INDUSTRIAL WORKSHOP EQUIPMENT

First stage: 60,000kg safe working capacity
Second stage: 40,000kg safe working capacity
Third stage: 20,000kg safe working capacity
First stage hydraulic lift: 57mm
Second stage hydraulic lift: 59mm
Third stage hydraulic lift: 61mm
Height: 150-447mm
Adaptors: 45 and 75mm
Operating air pressure: 145-175psi
Handle length: 1380mm
Chassis: 875 x 295 x 150mm

LIFTS
60,000KG

INDUSTRIAL QUALITY

SUPER DEEP SUPER LOW

Includes
Height
Adaptors

Excludes GST
\$4099
Inc. GST \$4508.90



AIR ACTUATED 2 STAGE TRUCK JACK 25,000/50,000KG

BTJ2550TA **BORUM**
INDUSTRIAL WORKSHOP EQUIPMENT

Stage 1: 50,000kg safe working capacity
Stage 2: 25,000kg safe working capacity
Lift range: 215-564mm
Hydraulic lift: Stage1: 115mm, Stage2: 114mm
Adaptors: 45, 75mm
Handle length: 1380mm
Operating air pressure: 145-175psi
Chassis: 805L x 282H x 215Wmm

Excludes GST
\$3699
Inc. GST \$4068.90

Includes
Height
Adaptors

INDUSTRIAL QUALITY

LIFTS
50,000KG

DEEP REACH LOWER PROFILE

FEATURES

Double sealing function - XTP industry sealing.
Telescopic air actuation lift.
Self-returning lowering and lifting switch.
Internal & external cylinders hard chromed
Long T-handle for high manoeuvrability & deep reach under vehicles.



AIR ACTUATED 2 STAGE TRUCK JACK 50,000/80,000KG

BTJ5080TA **BORUM**
INDUSTRIAL WORKSHOP EQUIPMENT

First stage: 80,000kg safe working capacity
Second stage: 50,000kg safe working capacity
First stage hydraulic lift: 111mm
Second stage hydraulic lift: 102mm
Height: 230-563mm
Adaptors: 45 and 75mm
Operating air pressure: 145-175psi
Handle length: 1300mm
Chassis: 930 x 340 x 230mm

LIFTS
80,000KG

INDUSTRIAL QUALITY

SUPER DEEP SUPER HIGH LIFT SUPER HIGH CAPACITY

Excludes GST
\$4599
Inc. GST \$5058.90

Includes
Height
Adaptors



AIR ACTUATED 3 STAGE TRUCK JACK 10,000/25,000/50,000KG

BTJ102550TA **BORUM**
INDUSTRIAL WORKSHOP EQUIPMENT

Safe working capacity: Stage1: 10,000kg
Stage2: 25,000kg, Stage3: 50,000kg
Lift range: 160-472mm
Hydraulic lift: Stage1: 62mm
Stage2: 61mm, Stage3: 69mm
Adaptors: 45, 75mm
Handle length: 1380mm
Operating air pressure: 145-175psi
Chassis: 825L x 282H x 160Wmm

LIFTS
50,000KG

INDUSTRIAL QUALITY

Includes
Height
Adaptors

FEATURES

Double sealing function using XTP industry sealing.
Telescopic air actuation lift.
Self-returning lowering and lifting switch.
Internal & external cylinders hard chromed
Long T-handle for high manoeuvrability & deep reach under vehicles.

Excludes GST
\$3669
Inc. GST \$4035.90

FEATURES

Double sealing function using XTP industry sealing.
Telescopic air actuation lift (air-hydraulic pump).
Long T-handle lets you easily position your jack under vehicle.
Self-returning lowering and lifting switch.
Internal and external cylinders hard chromed.
High manoeuvrability & deep reach under vehicles.
2 extension adaptors / saddle plates.
Large rubber wheels.



DEEP REACH LOWER PROFILE



MADE FOR THE TRADE

HYDRAULIC BOTTLE JACKS

TRADEQUIP
The trusted brand in equipment

**HEAVY DUTY
One Piece
Ergonomic
Handle**

YouTube

Scan code for online product maintenance demonstration

FEATURES

Machined and polished cylinders with die-cut threads provide non-abrasive leak-free, durable performance. Fabricated from hard-cast steel with heat-treated critical stress areas. Unique cross-type forged release valve ensures positive load control. Overload protection Hydraulic system is protected from internal damage by a by-pass mechanism. High quality glide-action pressure pump. Supplied with 500mm pump handle.

from
**Excludes GST
\$104**
Inc. GST \$114.40

| Code | 2012 | 2013 | 2014 | 2015 | 2016 |
|-------------------|-----------------|-----------------|-----------------|-----------------|-----------------|
| Capacity | 10,000kg | 15,000kg | 20,000kg | 12,000kg | 20,000kg |
| Hydraulic Lift | 125mm | 125mm | 145mm | 85mm | 115mm |
| Adjustable Height | 70mm | 70mm | 60mm | 50mm | 75mm |
| Min. Height | 205mm | 227mm | 245mm | 180mm | 200mm |
| Max. Height | 400mm | 447mm | 450mm | 315mm | 390mm |
| Base Area | 124x124mm | 148x136mm | 167x156mm | 157x134mm | 167x156mm |
| Excl. GST | \$104 | \$125 | \$163 | \$122 | \$162 |
| Incl. GST | \$114.40 | \$137.50 | \$179.30 | \$134.20 | \$178.20 |

AIR/HYDRAULIC BOTTLE JACK 12,000KG

TQBJ12TA TRADEQUIP
The trusted brand in equipment

Safe working capacity: 12,000kg
Working height: 260-510mm
Adjustable screw: 80mm
Work pressure: 110-125psi
Hydraulic stroke: 170mm
Air inlet fitting: 1/4"

MADE FOR THE TRADE

FEATURES
Compact powerful Air Turbo motor.
Versatile "quick connector" provides "quick & easy air connection."
Two piece pump handle.
Convenient welded carry handle.



**Excludes GST
\$219**
Inc. GST \$240.90

**12,000kg
Capacity**

AIR/HYDRAULIC SQUAT JACK 20,000KG

TQBJ20TAS TRADEQUIP
The trusted brand in equipment

Safe working capacity: 20,000kg
Working height: 178-328mm
Adjustable screw: 63mm
Work pressure: 110-125psi
Hydraulic stroke: 87mm
Air inlet fitting: 1/4"

MADE FOR THE TRADE

**Excludes GST
\$299**
Inc. GST \$328.90



**20,000kg
Capacity**

YouTube

Scan code for online product maintenance demonstration

AIR/HYDRAULIC BOTTLE JACK 20,000KG

2026T TRADEQUIP
The trusted brand in equipment

Safe working capacity: 20,000kg
Working height: 265-510mm
Hydraulic lift: 170mm (265mm to 435mm)
Adjustable height: 75mm (max. height 510mm)
Base area: 224x134mm
Work pressure: 90-120psi
Weight: 16kg

FEATURES
Compact powerful Air Turbo motor.
Versatile "quick connector" provides "quick & easy air connection."
Two piece pump handle.
Convenient welded carry handle.



**Excludes GST
\$279**
Inc. GST \$306.90

MADE FOR THE TRADE

AIR ACTUATED SUPER LOW PROFILE JACK 20,000KG

2051T TRADEQUIP
The trusted brand in equipment

Safe working capacity: 20,000kg
Working height: 148-259mm
Screw extension height: 45mm
Operating air pressure: 100-145psi
Hydraulic stroke: 66mm
Air inlet fitting: 1/4"

MADE FOR THE TRADE

**Excludes GST
\$369**
Inc. GST \$405.90



**20,000kg
Capacity**

FEATURES
Compact powerful Air Turbo motor.
Versatile "quick connector" provides "quick & easy air connection."
Chrome plated rams.
Convenient welded carry handle.

FEATURES OF TQ Pro BOTTLE JACKS

Using CNC technology, TQ Pro products are constructed using superior-grade steel and built to premium TQ Pro standards for professional quality and durability. Premium quality large diameter hydraulic steel cylinders are machined with precision tolerances, then treated and polished to minimise wear and extend service life. Incorporating the latest technology in aggressive wiping lips and OD exclusion, the high capability premium quality seal systems efficiently protect internal hydraulics keeping it free from dirt, mud, water, and other contaminants. A lead-free paint finish is applied after a thorough chemical wash to ensure a long-lasting premium finish with a final coat that is oil, grease and dirt-resistant for easy cleanup.



Professional Reputable Outstanding

AIR/HYDRAULIC BOTTLE JACK 20,000KG

PROBJ20TA

Safe working capacity: 20,000kg
Working height: 261.5-525mm
Hydraulic lift: 156mm
Adjustable lift: 95mm
Operating air pressure: 110-125psi
Air inlet fitting: 1/4"
Base: 230 x 150 x 30mm
Weight: 19kg



20,000kg Capacity



Professional Reputable Outstanding

Excludes GST \$449
Inc. GST \$493.90

WELDED BASE

AIR ACTUATED BOTTLE JACK SQUAT 20,000KG

PROBJ20TAS

Safe working capacity: 20,000kg
Working height: 185-330mm
Hydraulic lift: 80mm
Adjustable height: 110-125psi
Air inlet fitting: 1/4"
Base: 230 x 150 x 30mm
Weight: 16kg



20,000kg Capacity



Professional Reputable Outstanding

Excludes GST \$449
Inc. GST \$493.90

WELDED BASE

AIR/HYDRAULIC BOTTLE JACK 30,000KG

PROBJ30TA

Safe working capacity: 30,000kg
Working height: 279.5-533mm
Hydraulic lift: 155mm
Op. air pressure: 110-125psi
Air inlet fitting: 1/4"
Base: 250 x 180 x 40mm
Weight: 29kg



30,000kg Capacity



Professional Reputable Outstanding

Excludes GST \$589
Inc. GST \$647.90

WELDED BASE



BORUM BOTTLE JACK FEATURES

Manufactured of superior-grade steel and built to exacting standards for quality and durability. Lead-free paint finish is oil, grease and dirt-resistant. Built-in by-pass device protects hydraulic system. Compact, powerful Air Turbo Motor. High quality large diameter hydraulic steel cylinder. Precision machined, chrome plated and polished piston-ram. Versatile "quick connector" for easy removal of air hose.



Scan code for online product maintenance demonstration

AIR/HYDRAULIC BOTTLE JACK 20,000KG

BTSJ20TB BORUM INDUSTRIAL WORKSHOP EQUIPMENT

Safe working capacity: 20,000kg
Working height: 262 - 504mm
Hydraulic lift: 163mm
Op. air pressure: 110-125psi
Air inlet fitting: 1/4"
Weight: 16kg



20,000kg Capacity

Excludes GST \$349
Inc. GST \$383.90

INDUSTRIAL QUALITY

AIR/HYDRAULIC BOTTLE JACK 20,000KG

BWBBJ20T BORUM INDUSTRIAL WORKSHOP EQUIPMENT

Safe working capacity: 20,000kg
Working height: 263 - 503mm
Hydraulic lift: 160mm
Adjustable height: 80mm
Base area: 200x152mm
Op. air pressure: 90-120psi



20,000kg Capacity

Excludes GST \$389
Inc. GST \$427.90

INDUSTRIAL QUALITY

WELDED BASE

AIR/HYDRAULIC BOTTLE JACK 30,000KG

BWBBJ30T BORUM INDUSTRIAL WORKSHOP EQUIPMENT

Safe working capacity: 30,000kg
Working height: 275 - 532mm
Hydraulic lift: 162mm
Adjustable height: 95mm
Base area: 229x180mm
Op. air pressure: 90-120psi



30,000kg Capacity

Excludes GST \$499
Inc. GST \$548.90

INDUSTRIAL QUALITY

WELDED BASE

TOO NEW TO PHOTOGRAPH. VISIT WWW.TQB BRANDS.COM.AU FOR UPDATED IMAGES AND MORE SPECS.

AIR/HYDRAULIC BOTTLE JACK 35,000KG

BBJ35TA BORUM INDUSTRIAL WORKSHOP EQUIPMENT

Safe working capacity: 35,000kg
Working height: 264 - 414mm
Hydraulic lift: 150mm
Operating air pressure: 110-125psi
Air inlet fitting: 1/4"
Weight: 29kg



35,000kg Capacity

Excludes GST \$520
Inc. GST \$572.00

INDUSTRIAL QUALITY

WORKSHOP PRESS 20,000KG

1061T **TRADEQUIP**
The trusted brand in equipment.

Safe working capacity: 20,000kg
Working range: 63-783mm
Overall height: 1503mm
Overall width: 700mm
Overall depth: 660mm
Bed width: 504mm
Piston ram stroke: 160mm
Weight: 89kg



FEATURES

High-grade Channel Steel.
Hydraulics are powered with a high quality oil.
Integrated overload protection valve keeps from overloading the system.
Lead-free paint finish is oil, grease and dirt-resistant for easy cleanup and to help prevent rust.



Excludes GST

\$569

Inc. GST \$625.90

HYDRAULIC WORKSHOP PRESS 20,000KG

1063T **TRADEQUIP**
The trusted brand in equipment.

Safe working capacity: 20,000kg
Working range: 30-870mm
Overall height: 1795mm
Overall width: 780mm
Overall depth: 655mm
Bed width: 505mm
Piston ram stroke: 185mm
Weight: 89.5kg



FEATURES

High-grade Channel Steel.
100mm pressure gauge.
High quality large diameter hydraulic steel cylinder unit.
Hydraulics are powered with a high quality oil.
Integrated overload protection valve keeps from overloading the system.
Lead-free paint finish is oil, grease and dirt-resistant for easy cleanup and to help prevent rust.

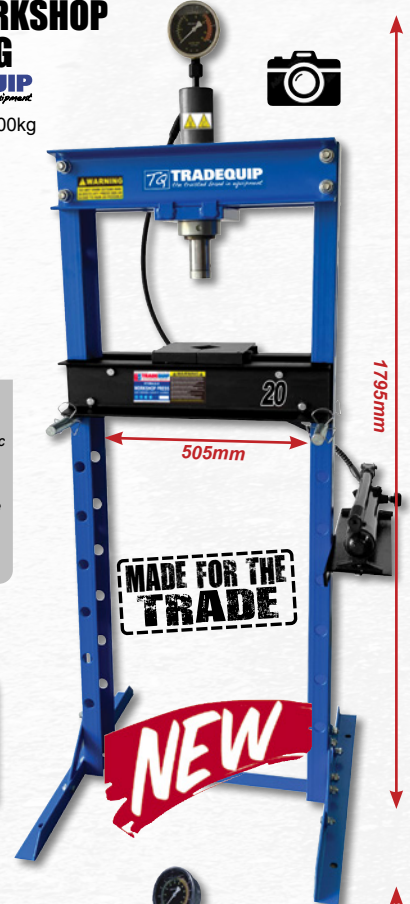

Excludes GST

\$899

Inc. GST \$988.90



TOO NEW TO PHOTOGRAPH. VISIT WWW.TQBBrands.COM.AU FOR UPDATED IMAGES AND MORE SPECS.

WORKSHOP PRESS 30,000KG

1062T **TRADEQUIP**
The trusted brand in equipment.

Safe working capacity: 30,000kg
Working range: 50-710mm
Overall height: 1605mm
Overall width: 743mm
Overall depth: 660mm
Bed width: 638mm
Piston ram stroke: 165mm
Weight: 112kg



FEATURES

High-grade Channel Steel.
Hydraulics are powered with a high quality oil.
Integrated overload protection valve keeps from overloading the system.
Lead-free paint finish is oil, grease and dirt-resistant for easy cleanup and to help prevent rust.



Excludes GST

\$929

Inc. GST \$1021.90

HYDRAULIC WORKSHOP PRESS 30,000KG

1064T **TRADEQUIP**
The trusted brand in equipment.

Safe working capacity: 30,000kg
Working range: 50-1030mm
Overall height: 1645mm
Overall width: 720mm
Overall depth: 660mm
Bed width: 460mm
Piston ram stroke: 170mm
Weight: 138kg



FEATURES

High-grade Channel Steel.
100mm pressure gauge.
High quality large diameter hydraulic steel cylinder unit.
Hydraulics are powered with a high quality oil.
Integrated overload protection valve keeps from overloading the system.
Lead-free paint finish is oil, grease and dirt-resistant for easy cleanup and to help prevent rust.



Excludes GST

\$1299

Inc. GST \$1428.90

HYDRAULIC WORKSHOP PRESS 50,000KG

2048T **TRADEQUIP**
The trusted brand in equipment
 Safe working capacity: 50,000kg
 Working range: 137-837mm
 Bed outside: 356mm
 Bed inside: 200mm
 Bed width: 710mm
 Bed internal: 390 x 200mm
 Piston ram stroke: 190mm
 Ram diameter: 95mm
 Op. air pressure: 110-125 psi
 1700H x 1290W x 745Dmm
 Bed height settings: 6
 Weight: 271kg

Excludes GST
\$2499
 Inc. GST \$2748.90

NEW

6 HEIGHT SETTINGS

FEATURES
 Heavy-duty high-grade steel frame.
 Hand operated air trigger ram travel control.
 100mm pressure gauge.
 Polished pneumatic aluminium air motor.
 Bed winch for easy raise and lower adjustment.
 Lead-free paint finish helps prevent rust & is oil, grease and dirt-resistant.
 High quality large diameter hydraulic unit.
 Hand winch for fast height adjustments.

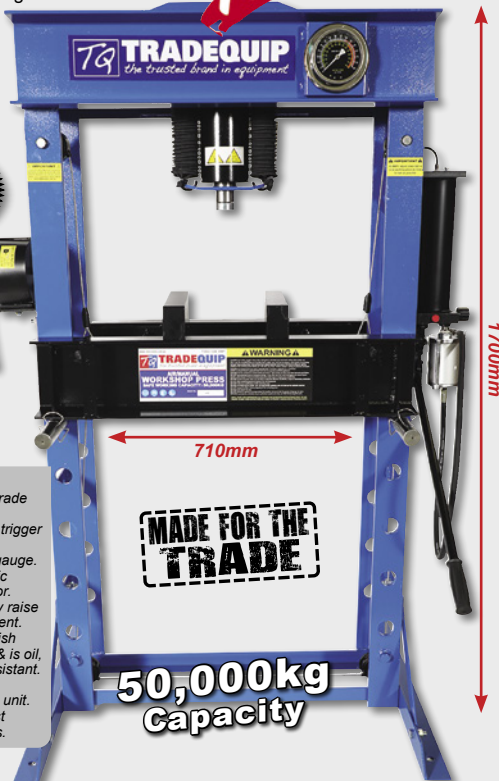

MADE FOR THE TRADE

50,000kg Capacity

WORKSHOP PRESS ADAPTOR KIT

BPAK **FORUM**
 INDUSTRIAL WORKSHOP EQUIPMENT

INDUSTRIAL QUALITY

Includes 8 different sized pins (mandrels) ranging from 2,000kg to 20,000kg capacity, a pin holder, a storage shelf along with a mounting kit, and a pin plate with the weight capacity shown for each pin.
 This very handy set of eight steel mandrels, adaptor and press plate expands the uses of your workshop press for a wider range of applications involving different sized work pieces.

(Mandrel Length x Diameter)
 50mm x 10mm
 60mm x 12mm
 60mm x 16mm
 85mm x 18mm
 85mm x 20mm
 85mm x 22mm
 15mm x 25mm
 110mm x 30mm

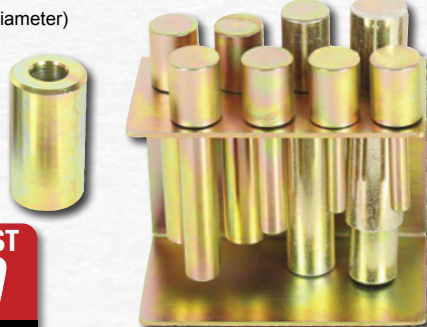

Excludes GST
\$179
 Inc. GST \$196.90

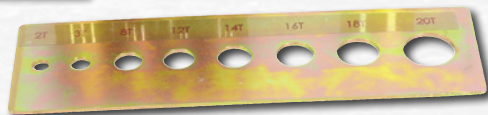

HYDRAULIC WORKSHOP PRESS 45,000KG WIDE

2036T **TRADEQUIP**
The trusted brand in equipment
 Safe working capacity: 45,000kg
 Working range: 159-859mm
 Bed outside: 359mm
 Bed inside: 195mm
 Bed width: 826mm
 Piston ram stroke: 190mm
 Ram diameter: 90mm
 1707H x 1406W x 826Dmm
 Bed height settings: 6
 Weight: 296kg

Excludes GST
\$3299
 Inc. GST \$3628.90

6 HEIGHT SETTINGS

Bed winch

FEATURES
 High-grade steel frame.
 100mm pressure gauge.
 Bed winch for easy raise and lower adjustment.
 Lead-free paint finish is oil, grease and dirt-resistant.
 Hand winch for fast adjustment.

MADE FOR THE TRADE



45,000kg Capacity

AIR/HYDRAULIC WORKSHOP PRESS 45,000KG WIDE

2038T **TRADEQUIP**
The trusted brand in equipment
 Safe working capacity: 45,000kg
 Working range: 159-859mm
 Bed outside: 359mm
 Bed inside: 195mm
 Bed width: 826mm
 Piston ram stroke: 190mm
 Ram diameter: 90mm
 Op. air pressure: 110-125 psi
 1707H x 1406W x 800Dmm
 Bed height settings: 6
 Weight: 301kg
AIR OPERATED

6 HEIGHT SETTINGS

Bed winch

MADE FOR THE TRADE

FEATURES
 High-grade steel frame.
 2 speed pump. 100mm pressure gauge.
 Bed winch for easy raise and lower adjustment.
 Paint is oil, grease and dirt-resistant for easy cleanup.
 High quality large diameter hydraulic steel cylinder unit.
 Piston-ram is treated, polished. Includes hand winch.
 Integrated overload protection valve prevents overloading.
 Extra-long handle included for easy pumping force.
 Double spring ram return for fast ram retraction.



45,000kg Capacity

Excludes GST
\$3499
 Inc. GST \$3848.90

AIR/HYDRAULIC WORKSHOP PRESS 30,000KG

PROSHPR30TA

Safe working capacity: 30,000kg
Working range: 25-850mm
Screw adjustment: 75mm
Bed outside: 164mm
Bed inside: 148mm
Bed width: 600mm
Ram diameter: 58mm
Bed height settings: 6
1800H x 770W x 505Dmm
Weight: 163kg

TQ PRO
LATEST APPLIED TECHNOLOGIES
Professional Reputable Outstanding
Trusted by serious professionals

30,000kg Capacity

TQ PRO
LATEST APPLIED TECHNOLOGIES
Trusted by serious professionals

- ✓ Mandrel Kit Included
- ✓ Long Pump Handle
- ✓ Premium Bed Blocks
- ✓ Winch Adjustable Bed
- ✓ Premium Hydraulic System
- ✓ Premium Paint Finish
- ✓ Precision Lateral Ram Adjustment
- ✓ Premium Grade Steel Construction
- ✓ Designed for maximum strength, reliability and durability
- ✓ Foot Pedal Air/Hydraulic Operation

YouTube

Scan code for TQPro Presses online product demonstration

AIR/HYDRAULIC WORKSHOP PRESS 50,000KG

PROSHPR50TA

Safe working capacity: 50,000kg
Working range: 80-780mm
Screw adjustment: 75mm
Bed inside: 200mm
Bed outside: 220mm
Bed width: 750mm
Ram diameter: 68mm
Bed height settings: 6
1900H x 930W x 535Dmm
Weight: 243kg

TQ PRO
LATEST APPLIED TECHNOLOGIES
Professional Reputable Outstanding
Trusted by serious professionals



50,000kg Capacity

AIR/HYDRAULIC WORKSHOP PRESS 75,000KG

BSP75TA **BORUM**
INDUSTRIAL WORKSHOP EQUIPMENT

Safe working capacity: 75,000kg
Working range: 170-884mm
Piston ram stroke: 260mm
Bed height settings: 8
Bed width: 800mm
Op. air pressure: 110-125psi
1925H x 1446W x 800Dmm
Weight: 451kg

INDUSTRIAL QUALITY

FEATURES

High-grade steel H-frame.
Foot operated air trigger ram travel control.
100mm pressure gauge.
Table winch system lowers or raises the bed.
High quality large diameter hydraulic steel cylinder unit.
Hydraulics are powered with a high quality oil.
Integrated overload protection valve keeps from overloading the system.
Lead-free paint finish is oil, grease and dirt-resistant for easy cleanup and to help prevent rust.
Extra tall working range.
Pair of bed plates included.

AIR/HYDRAULIC WORKSHOP PRESS 100,000KG

BSP100TA **BORUM**
INDUSTRIAL WORKSHOP EQUIPMENT

Safe working capacity: 100,000kg
Working range: 113-813mm
Piston ram stroke: 300mm
Bed height settings: 6
Bed width: 787mm
Op. air pressure: 110-125psi
2048H x 1499W x 990Dmm
Air inlet: 1/4"NPT
Weight: 652kg

100,000kg Capacity

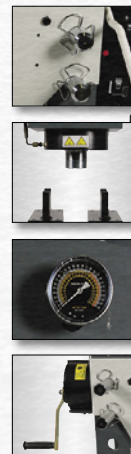

INDUSTRIAL QUALITY

Excludes GST \$11,499
Inc. GST \$12,648.90

HYDRAULIC WORKSHOP PRESS 20,000KG

BHSP20T **BORUM**
INDUSTRIAL WORKSHOP EQUIPMENT

Safe working capacity: 20,000kg
Working range: 38-918mm
Bed outside: 172mm
Bed inside: 152mm
Bed width: 510mm
Piston ram stroke: 185mm
Bed height settings: 8
Ram diameter: 72mm
1626H x 755W x 560Dmm
Weight: 115kg

INDUSTRIAL QUALITY

FEATURES

Heavy-duty high-grade steel H-frame. Integrated overload protection valve. Foot & Hand operated pump. 100mm pressure gauge. **STEEL SAFETY MESH BARRIER** Lead free paint finish is oil, grease and dirt-resistant for easy cleanup. Piston-ram is fitted with backup ring, preventing bypass oil drift. High quality hydraulic oil offers better corrosion resistance and flexibility. Pair of bed plates included.

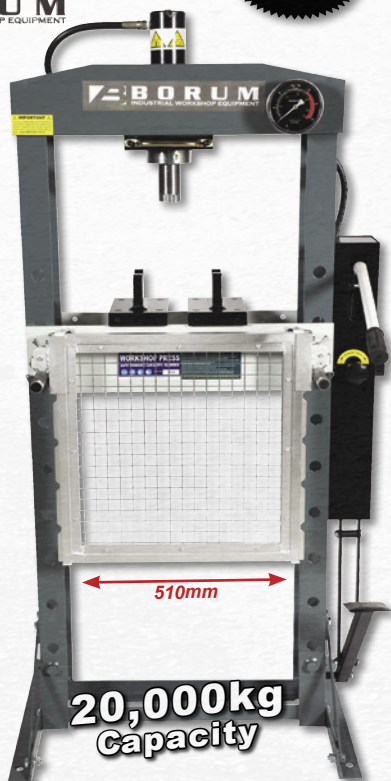

Excludes GST
\$2049
Inc. GST \$2253.90

HYDRAULIC WORKSHOP PRESS 30,000KG

BHSP30T **BORUM**
INDUSTRIAL WORKSHOP EQUIPMENT

Safe working capacity: 30,000kg
Working range: 151-1031mm
Bed outside: 184mm
Bed inside: 164mm
Bed width: 535mm
Piston ram stroke: 150mm
Bed height settings: 8
Ram diameter: 80mm
1830H x 1000W x 700Dmm
Weight: 167kg

INDUSTRIAL QUALITY

FEATURES

Heavy-duty high-grade steel H-frame. Integrated overload protection valve. Foot & Hand operated pump. 100mm pressure gauge. **STEEL SAFETY MESH BARRIER** Lead free paint finish is oil, grease and dirt-resistant for easy cleanup. Piston-ram is fitted with backup ring, preventing bypass oil drift. High quality hydraulic oil offers better corrosion resistance and flexibility. Pair of bed plates included.

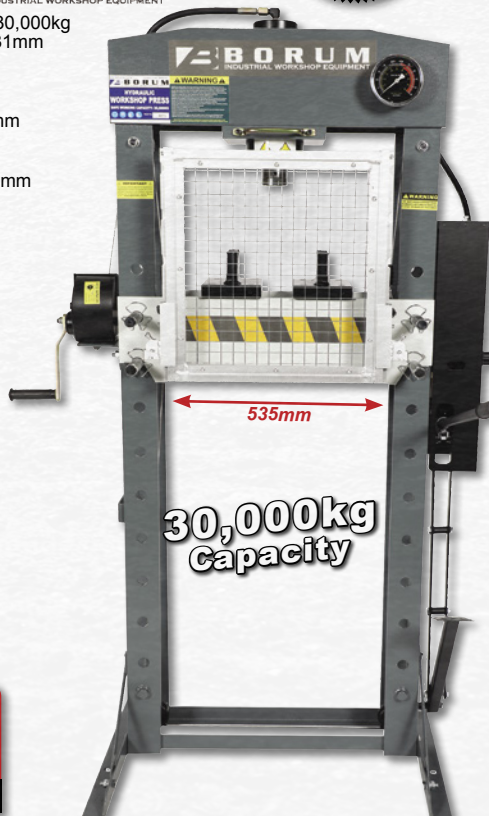

Excludes GST
\$2899
Inc. GST \$3188.90

HYDRAULIC GEAR PULLER 23 PIECE

9023T **TRADEQUIP**
The trusted brand in equipment

Capacity: 10,000kg
Bearing Separator: 20-105mm
Twin/triple head, beam and legs to build: 100, 150 and 200mm
Two and three leg hydraulic pullers with separator capacity: 75-105mm
Size: 355L x 195W x 150Hmm

MADE FOR THE TRADE

Pulls bearings, timing gears, steering wheels and pulleys on most cars and light trucks



Excludes GST
\$349
Inc. GST \$383.90

UNIVERSAL PRESS & PULL SLEEVE KIT 26 PIECE

9024T **TRADEQUIP**
The trusted brand in equipment

4 Beams
3 1/2" Sleeves
20 Sleeves
11pieces (GOLD)
9 pieces (SILVER)

MADE FOR THE TRADE

For removal and installation of bushes, bearings and seals, races, sprockets and pulleys on cars, trucks, off-road construction equipment and machinery



UNIVERSAL PRESS SUPPORT BLOCK 30,000KG

9025T **TRADEQUIP**
The trusted brand in equipment

Base block: 250 x 200 x 40mm
Height adaptor block: 200x70x40mm

Made from Billet aluminium

For use with a hydraulic shop press for workpieces with a complicated shape to allow bearings to be pressed in or out accurately.

Excludes GST
\$338
Inc. GST \$371.80



TRANSFORM YOUR

WORKSHOP MATE WORKSTATION FEATURING A 30,000KG SHOP PRESS & SPRING COMPRESSOR

WSM4

- Safe working capacity: 30,000kg
- Working range: 224mm-819mm
- Piston ram stroke main ram: 140mm (Standard load cap fitted)
- Bed height settings: 85mm increments – 8 settings
- Bed width: 466mm
- Bed gap: 200mm
- Spring compressor:
- Piston ram stroke: 295mm
- Operating air pressure: 90-125psi
- Overall dimensions: 1820H x 1170W x 820Dmm
- Weight: 400kg

Designed for:
Front Struts, Rear Axles
4x4 Struts
Bushes and Ball Joints
Hubs & Wheel Bearings

NEW



MADE FOR THE TRADE

YouTube
 Scan code for online product demonstration

FEATURES
 AIR/HYDRAULIC OPERATED 30,000KG PRESS
 SPRING COMPRESSOR. FILTER CRUSHING ACCESSORY
 DOZENS OF UNIQUE TOOLING OPTIONS
 ON-BOARD TOOLING STORAGE STAND
 WINCH OPERATION TO LOWER AND RAISE BENCH

BENEFITS
 Press almost any bearing or bush with **PRECISION** and **ACCURACY** in minutes, saving valuable workshop time.
 Smooth **AIR/HYDRAULIC** foot pedal operation for hands-free accuracy & control.
 Hands free Spring Compression.
 Even the most difficult pressing tasks become **SAFE & EASY**.
 Complete with **COMPREHENSIVE HIGH QUALITY** Interlocking Tool, Die and Spacer Kit to ensure **SAFE WORK PRACTICES**.
 Complete on machine storage - minimises time spent searching for the required tools & spacers for each job!
 Tasks like **SUSPENSION BUSHES** once seen as too hard become a breeze.
 A comprehensive variety of spring adaptors, suitable to almost any type or model of spring **SAFE & EASY** to compress in **MINUTES!**
 Decrease labour time and increase productivity and efficiencies.
 Increase Workplace Safety.
 Undertake jobs that are currently too difficult.



*Additional Freight Rates may apply

WORKSHOP MATE

WORKSHOP

Excludes GST
\$7999
Inc. GST \$8798.90



Visit our webpage
www.tqbbrands.com.au
for more specifications
and images

***FREIGHT
RATES WILL
APPLY**

***NOTE: ADDITIONAL TOOLING MAY BE REQUIRED FOR SOME APPLICATIONS**

FOLDING STABILISER ARMS

DUAL ACTION HIGH SPEED RAM

1200kg Capacity

1565mm

1690mm

1028mm

MEETS AUSTRALIAN STANDARD AS1418:5

FOLDABLE ENGINE CRANE 1,200KG

1001T TRADEQUIP
The trusted brand in equipment

Safe working max. capacity: 1200kg (AS1418.5 approved)
Adjustable boom: 250kg, 500kg, 750kg & 1200kg
Max. lifting height @ 1200kg: 620mm
Max. lifting height @ 250kg: 1160mm
Jib length fully retracted @ 1200kg: 1040mm
Jib length fully extended @ 250kg: 1580mm
Leg height: 190mm
Weight: 85kg

MADE FOR THE TRADE

FEATURES

Ideal for automotive & light engineering.
Adjustable boom in four positions.
Outrigger legs easily fold up for storage.
Six swivel castor wheels.
High-grade steel and built to exacting standards for quality and durability.
Short lifting chain & hook with safety latch.
Lead-free paint is oil, grease and dirt-resistant for easy cleanup.



ENGINE SUPPORT BAR

1021T TRADEQUIP
The trusted brand in equipment

Safe working capacity: 500kg
Extension: 1020 - 1630mm
Weight: 23kg

FEATURES

Cross bar feature for improved stability and more flexibility.
Dual hook assemblies for balanced support of engines & transmissions.
High gloss enamel finish.
Adjustment screw for leveling.

500kg Capacity

DUAL HOOK

Adjustable Extension Arms

MADE FOR THE TRADE

Excludes GST \$245
Inc. GST \$269.50

ENGINE SUPPORT BAR

1019T TRADEQUIP
The trusted brand in equipment

Safe working capacity: 500kg
Extension: 1020 - 1600mm
Weight: 15kg

FEATURES

Adjusts to fit across most car bonnets.
Supports engines or transmissions.
Powder coat finish.
Adjustment screw for load leveling.
Supplied with short length of chain.

500kg Capacity

Adjustable Extension Arms

MADE FOR THE TRADE

Excludes GST \$169
Inc. GST \$185.90

RAM TO SUIT TRADEQUIP 1001T ENGINE CRANE

2008 TRADEQUIP
The trusted brand in equipment

Safe working capacity: 8,000kg
Length: 630-1135mm
Ram pin hole: 16mm dia. 35mm Outside ram
Ram diameter: 80mm
Clevis base pin hole: 16mm dia
Clevis base: 25mm inside - 45mm outside
Base width: 129mm
Weight: 10.5kg

MADE FOR THE TRADE

Excludes GST

\$164

Inc. GST \$180.40

8000kg Capacity

ENGINE SUPPORT BAR

1020T TRADEQUIP
The trusted brand in equipment

Safe working capacity: 500kg
Extension: 1020- 1430mm
Weight: 19kg

Adjustable Extension Arms

FEATURES

Dual hook assemblies for balanced support.
Adjustable to fit across most car bonnets.
Supports engines or transmissions.
Rubber cushioned support legs.
High gloss enamel finish.
Adjustment screw for load leveling.
Supplied with a short length of chain.

500kg Capacity

Adjustable Extension Arms

MADE FOR THE TRADE

Excludes GST \$194
Inc. GST \$213.40

DUAL HOOK

ENGINE CRANE 3,000KG
1193 TRADEQUIP
The trusted brand in equipment

Safe working capacity: 3000kg
 Adjustable boom: 1000kg, 1500kg, 2000kg & 3000kg
 Maximum lifting height @ 3000kg: 1745mm
 Maximum lifting height @ 1000kg: 2088mm
 Jib length fully retracted @ 3000kg: 1100mm
 Jib length fully extended @ 1000kg: 1730mm
 Leg height 190mm
 Weight: 121.5kg

FEATURES
 This heavy duty TradeQuip "Made for the Trade" engine crane has a long stroke lifting ram, a single action pump with a maximum load capacity of 3,000kg.
 Very simple to use manual hydraulic operation. The jib extends to the desired lifting capacity of 1000kg, 2000kg or 3000kg secured by a single locking pin.
 Mounted on heavy duty castor wheels for excellent manoeuvrability around the workshop.

MADE FOR THE TRADE

4 position adjustable boom

Heavy duty hydraulic pump

Excludes GST \$1238
 Inc. GST \$1361.80

3000kg Capacity

Heavy Duty Castor Wheels

1540mm

1470-2385mm

785-875mm

HEAVY DUTY



ENGINE STAND
1894T TRADEQUIP
The trusted brand in equipment

Safe Working Capacity: 4/5/6/V6 cylinder less than 4ltr
 Rated capacity: 500kg
 360° rotating head
 1190L x 850W x 1230H mm
 Weight: 54kg

WORM GEAR HEAD DRIVE STURDY REINFORCED NECK

360° rotating head

IMPORTANT:
 ENGINE DIMENSIONS MUST BE WITHIN LEGS OF ENGINE STAND

Excludes GST \$789
 Inc. GST \$867.90

MADE FOR THE TRADE

SCAN BEFORE CHOOSING YOUR STAND

ENGINE STAND
1891T TRADEQUIP
The trusted brand in equipment

Safe working capacity: 4cylinder & V6/V8 less than 5ltr
 Rated capacity: 680kg
 360° rotating head
 Centre height: 895mm
 870L x 800W x 900H mm
 Weight: 39kg

360° rotating head

Removable legs

Excludes GST \$267
 Inc. GST \$293.70

MADE FOR THE TRADE

ENGINE STAND
TQES450 TRADEQUIP
The trusted brand in equipment

Safe working capacity: 4cylinder engine only
 Rated capacity: 450kg
 360° rotating head
 Centre height: 780mm
 700L x 750W x 860H mm
 Weight: 21kg

360° rotating head

IMPORTANT:
 ENGINE DIMENSIONS MUST BE WITHIN LEGS OF ENGINE STAND

SPACE SAVING COMPACT DESIGN EASY SETUP & DISASSEMBLY

Excludes GST \$159
 Inc. GST \$174.90

MADE FOR THE TRADE

ENGINE STAND
1192T TRADEQUIP
The trusted brand in equipment

Safe working capacity: 4/5/6/V6/V8 Cylinder less than 6.2ltr
 Rated capacity: 900kg
 360° rotating head
 Centre height: 800mm
 1110L x 530W x 900H mm
 Weight: 45kg

360° rotating head

FOLDING LEGS FOR EASY STORAGE STURDY REINFORCED NECK AND STABLE WIDE BASE

Excludes GST \$328
 Inc. GST \$360.80

MADE FOR THE TRADE

WORKSHOP TROLLEY (Polymer)

6044T **TRADEQUIP**
the trusted brand in equipment

Safe working capacity: 226kg
Top tray: 778L x 415W x 63Hmm
Tray capacity: 113kg (each)
Smooth rolling rubber castors:
125D x 25Wmm
Ground clearance: 140mm
Weight: 14kg

Excludes GST
\$239
Inc. GST \$262.90



NEW
SUPER STRONG POLYMER

FEATURES

Will not dent, rust or chip.
Two deep shelves for plenty of storage.
Convenient push handle.
Two swivel and two fixed smooth rolling rubber castors.
No painting required. Cleans easily.
Virtually maintenance free.

MADE FOR THE TRADE

WORKSHOP TROLLEY (Polymer)

6045 **TRADEQUIP**
the trusted brand in equipment

Safe working capacity: 226kg
3 x 100mm deep shelves
125x30mm smooth rolling rubber swivel castors
75kg tool tray capacity
875L x 430W x 830Hmm

Excludes GST
\$263
Inc. GST \$289.30



NEW
SUPER STRONG POLYMER

FEATURES

Deep shelves give you plenty of storage for your tools and parts.
Industrial grade castors.
Will not dent, rust or chip.
Convenient push handles.
No painting required. Cleans easily.



TOO NEW TO PHOTOGRAPH. VISIT WWW.TQBBRANDS.COM.AU FOR UPDATED IMAGES AND MORE SPECS.

WORKSHOP TROLLEY (Polymer)

6042T **TRADEQUIP**
the trusted brand in equipment

Safe working capacity: 226kg
Tray: 900L x 600W x 65Hmm
Tray capacity: 113kg (each)
Smooth rolling rubber castors: 125D x 25Wmm
Ground clearance: 140mm
Weight: 22kg

Excludes GST
\$329
Inc. GST \$361.90

MADE FOR THE TRADE



FEATURES

Super strong polymer (heavy duty structural plastic) construction.
Will not dent, rust or chip.
Two deep and wide shelves for plenty of storage.
Convenient push handle.
Two swivel and two fixed smooth rolling rubber castors.
No painting required. Cleans easily.
Virtually maintenance free.

NEW
SUPER STRONG POLYMER

WORKSHOP TROLLEY (Polymer)

6043T **TRADEQUIP**
the trusted brand in equipment

Safe Working Capacity: 226kg
Tray Capacity: 76kg (each)
Tray: 900L x 600W x 65Hmm
Smooth Rolling Rubber Castors: 125D x 25Wmm
Ground Clearance: 140mm
Weight: 33.5kg

Excludes GST
\$379
Inc. GST \$416.90



MADE FOR THE TRADE



FEATURES

Super strong polymer (heavy duty structural plastic) construction.
Will not dent, rust or chip.
Three deep and wide shelves for plenty of storage.
Convenient push handle.
Two swivel and two fixed smooth rolling rubber castors.
No painting required. Cleans easily.
Virtually maintenance free.

NEW
SUPER STRONG POLYMER

MOBILE WORKSHOP TABLE

6024T **TRADEQUIP**
the trusted brand in equipment

45kg Capacity

Safe working capacity: 45kg
Working height: 930-1270mm
Castor wheel diameter: 75mm
Top dimensions: 809L x 475W x 42Hmm
Main tray dimensions: 580L x 308W x 38Hmm
Overall dimensions: 870L x 755W x 942Hmm
Weight: 19.5kg

FEATURES

The Heavy Duty steel construction.
Easily handles loads up to 45kg.
Solid composite rubber castors.
Simple height adjustment gives you plenty of options for lowered cars or SUV's.

Excludes GST
\$349
Inc. GST \$383.90

Lockable composite rubber castors

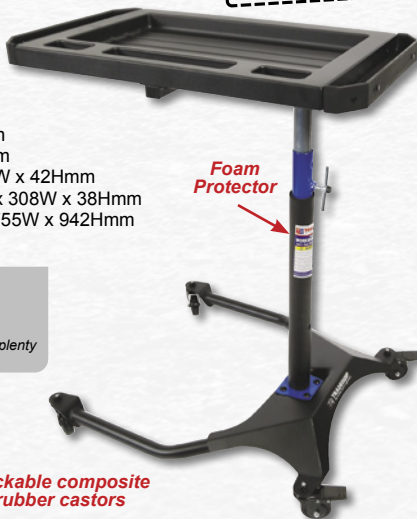

Foam Protector

MADE FOR THE TRADE

WORKSHOP TROLLEY (Polymer)

6046 **TRADEQUIP**
the trusted brand in equipment

Safe working capacity: 226kg
8 Parts bins 241x152x127mm
24 Parts bins 165x101x76mm
125x30mm rubber swivel castors
85kg tool tray capacity
1000L x 435W x 850Hmm

Excludes GST
\$365
Inc. GST \$401.50

SUPER STRONG POLYMER

Includes 32 Parts Bins

FEATURES

Deep shelves give you plenty of storage for your tools and parts.
Industrial grade castors.
Will not dent, rust or chip.
Convenient push handles.
No painting required. Cleans easily.

MADE FOR THE TRADE

*Additional Freight Rates may apply

WORKBENCHES/STORAGE

WORKSHOP TROLLEY 2 TOOL TRAYS & 1 DRAWER

6012T **TRADEQUIP**
The trusted brand in equipment

Safe working capacity: 100kg
One lockable drawer
100mm composite rubber castors
Two 100mm deep shelves
770L x 370W x 830Hmm



FEATURES

Heavy gauge steel construction.
Quality 35mm ball bearing slide drawer.
Side handle for comfort and control.
Tough enamel finish.

MADE FOR THE TRADE

Excludes GST

\$269

Inc. GST \$295.90



100kg Capacity

WORKSHOP TROLLEY 2 DRAWERS & LOCKABLE SLIDING TOP

6019T **TRADEQUIP**
The trusted brand in equipment

Safe working capacity: 100kg
Two lockable drawers & top
100mm composite rubber castors
Two 75mm deep shelves
700L x 370W x 760Hmm

MADE FOR THE TRADE

FEATURES

Heavy gauge steel construction with lockable sliding top.
Quality 35mm ball bearing sliding drawers, which are locked when top is closed.
Side handle for comfort/control when moving.
Tough enamel finish.
Non slip rubber tool tray liners.

Excludes GST

\$373

Inc. GST \$410.30



100kg Capacity

22 BIN PARTS STORAGE RACK

6053 **TRADEQUIP**
The trusted brand in equipment

Working load capacity: 100kg
15 parts bins: 345x105x75mm (3kg load capacity)
4 parts bins: 345x140x150mm (5kg load capacity)
3 parts bins: 345 x 205 x 150mm (8kg load capacity)
Swivel castor diameter: 100mm
880L x 410W x 950H mm

MADE FOR THE TRADE

Excludes GST

\$418

Inc. GST \$459.80



EASY TO ASSEMBLE

FEATURES

Sturdy five-tier steel powder coated rack.
Zinc plated wire shelving with bin locating guides.
Quick & easy clip together adjustable shelves.
Stackable bins made of moulded polypropylene.
Ideal for garage, workshop, office, shed.
Powder coat frame resists corrosion.
Quality swivel castors (2x lockable).
Convenient access to removable bins.

MOBILE WORKSHOP TABLE WITH DRAWER

6056T **TRADEQUIP**
The trusted brand in equipment

340x300x45mm drawer
Adjustable from 860-1200mm high
Includes drawer and top tray liner
80kg Distributed load capacity
730x500x25mm top tray

NEW

MADE FOR THE TRADE

FEATURES

Height adjustable for most vehicles.
Ball Bearing wheels for easy moving.
Multi-functional top table with 3 compartments and 6 screwdriver holes.
Top EVA mat for skid resistance.
Extra drawer for more storage room.

Excludes GST

\$259

Inc. GST \$284.90



WORKSHOP TROLLEY 4 DRAWERS WITH LOCKABLE TOP

6052 **TRADEQUIP**
The trusted brand in equipment

Working load limit: 260kg
Heavy duty steel construction
High gloss enamel paint finish
Non-slip rubber tool tray liners

MADE FOR THE TRADE

FEATURES

Quality ball bearing slide drawers, that are locked when top is closed.
Two heavy-duty locking castors for control and stability.

Includes bottom shelf and 4 locking drawers
850L x 445D x 972Hmm

Excludes GST

\$448

Inc. GST \$492.80



260kg Capacity

36 BIN PARTS STORAGE RACK

6054 **TRADEQUIP**
The trusted brand in equipment

Working load capacity: 200kg
15 parts bins: 345x105x75mm (3kg load capacity)
12 parts bins: 345x140x150mm (5kg load capacity)
9 parts bins: 345 x 205 x 150mm (9kg load capacity)
Swivel castor diameter: 100mm
880L x 410W x 1705Hmm

MADE FOR THE TRADE

Excludes GST

\$655

Inc. GST \$720.50



EASY TO ASSEMBLE

FEATURES

Sturdy nine-tier steel powder coated rack.
Zinc plated wire shelving with bin locating guides.
Quick & easy clip together adjustable shelves.
Stackable bins made of moulded polypropylene.
Ideal for garage, workshop, office, shed.
Powder coat frame resists corrosion.
Quality swivel castors (2x lockable).
Convenient access to removable bins.

MOBILE WORKBENCH

1073T **TRADEQUIP**
The trusted brand in equipment

Safe working capacity: 300kg
Work surface: 1100 x 700mm
1100L x 700W x 830H mm
Weight: 60kg

FEATURES

Sturdy steel construction.
High gloss enamel finish.
Quality castors - two fixed and two locking swivel.
Heavy-duty handle.

300kg Capacity

Versatile and undeniably strong, TradeQuip workbenches are developed with sophisticated designs to endure demanding industry and heavy duty commercial applications.



3 DRAWER STEEL WORKBENCH

1012T **TRADEQUIP**
The trusted brand in equipment

Safe working capacity: 300kg
Heavy duty steel construction
High gloss enamel paint finish
Includes bottom shelf & 3 locking drawers
Each drawer holds up to 50kg
2000L x 860H x 640Wmm

FEATURES

Manufactured from high quality, heavy-duty steel and features a large surface for more work space and an extended lip around the surface of the table.
The tough high gloss enamel paint finish is designed to provide years of protection against normal wear and tear.



STEEL WORKBENCH

1014T **TRADEQUIP**
The trusted brand in equipment

Safe working capacity: 90kg
Work surface: 1510x700mm
Raised edge height: 50mm
1520L x 710W x 830Hmm
Weight: 48kg

FEATURES

Sturdy steel construction.
High gloss enamel paint finish.
Raised protective edge to work surface.
Adjustable feet for levelling on uneven floors.
Quick and easy to assemble.
Easily wipe dirt and grime from surface with a soft cloth.



STEEL WALL MOUNTED TOOL CABINET

1011T **TRADEQUIP**
The trusted brand in equipment

Thickness: 1mm Steel Sheet
Lockable cupboards: 3
Adjustable shelves: 6
Peg board hooks: 6
1200L x 600H x 200W mm
Weight: 19kg

FEATURES

Three compartments each have 2 adjustable shelves.
Perforated and slotted back panel to allow for the hanging of tools.
High gloss enamel paint.
Includes mounting brackets.



MOBILE WORKBENCH

6047 **TRADEQUIP**
The trusted brand in equipment

Safe working capacity: 250kg
Bench top capacity: 150kg
Bench top: 1200L x 640Wmm
1200L x 640W x 875H mm
Shelf: 1110L x 460Wmm
Shelf capacity: 100kg
Weight: 56.5kg

250kg Capacity

FEATURES

Heavy duty rolled edge steel construction.
Convenient removable drain bowl.
13mm benchtop rim to contain leaking fluids when working on engines and transmissions.
Quality castors (2 swivel with brake).
Lockable steel drawer with ball bearing slides.
High gloss enamel paint finish.



Ideal for Engine and Transmission Rebuilds

BENCH VICES FIXED OR SWIVEL WITH ANVIL



FEATURES

Quality cast iron body with steel screw and handle. Made of tough cast iron, this TradeQuip bench vice has forged steel jaws to grip & keep your workpiece steady. The large anvil is perfect for shaping and fabrication work.

MADE FOR THE TRADE



from
Excludes GST \$142
Inc. GST \$156.20

Reinforced mounting lugs

| Code | 7000T | 7001T | 7002T | 7003T | 7004T | 7005T |
|------------------|-----------------|-----------------|-----------------|-----------------|-----------------|-----------------|
| Vice type | Fixed | Fixed | Fixed | Swivel | Swivel | Swivel |
| Jaw Width | 125mm | 150mm | 200mm | 125mm | 150mm | 200mm |
| Jaw Opening | 130mm | 150mm | 170mm | 140mm | 170mm | 220mm |
| Throat Depth | 69mm | 76mm | 88mm | 76mm | 86mm | 110mm |
| Anvil Size | 85x90mm | 100x105mm | 105x105mm | 106x106mm | 127x127mm | 147x147mm |
| Excl. GST | \$142 | \$198 | \$258 | \$208 | \$310 | \$422 |
| Incl. GST | \$156.20 | \$217.80 | \$283.80 | \$228.80 | \$341.00 | \$464.20 |

MULTI-PURPOSE BENCH VICE WITH PIPE JAWS 150MM



Jaw width: 150mm
Jaw opening: 140mm
Throat depth: 80mm
Anvil size: 80x65mm

Jaws rotate 360°

FEATURES

Body of rugged quality malleable cast iron. Forge hardened steel serrated jaws. Precision machined steel screw and handle. Reinforced mounting lugs. 360° Swivel base locks in place for greater versatility. Jaws rotate 360° and lock for unlimited positioning. Holds flat stock as well as round stock with the built-in pipe jaws. Large hardened anvil work surface.

Excludes GST \$384
Inc. GST \$422.40

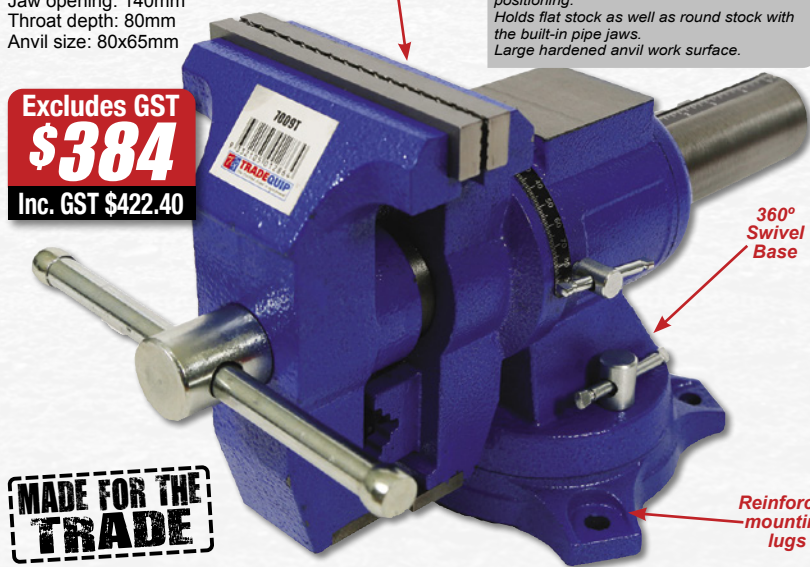

360° Swivel Base

Reinforced mounting lugs

MADE FOR THE TRADE

BENCH OFFSET VICE 150mm



Jaw width: 150mm
Jaw opening: 140mm
Throat depth: 103mm
Weight: 21kg

NEW

MADE FOR THE TRADE

Excludes GST \$388
Inc. GST \$426.80



FEATURES

Offset jaws allow the workpiece to be held in a vertical position. Fixed offset base - right hand. Solid fabricated steel construction. Precision machined screw & handle.

COMMERCIAL BENCH VICE SWIVEL WITH ANVIL 150MM



Jaw width: 150mm
Jaw opening: 150mm
Throat depth: 105mm
Anvil size: 90x105mm

INDUSTRIAL QUALITY



SG IRON

Excludes GST \$419
Inc. GST \$460.90

360° Swivel Base

COMMERCIAL BENCH VICE SWIVEL WITH ANVIL 200MM



Jaw width: 200mm
Jaw opening: 200mm
Throat depth: 115mm
Anvil size: 100x113mm

INDUSTRIAL QUALITY



SG IRON

Excludes GST \$599
Inc. GST \$658.90

360° Swivel Base

PARTS WASHER 90 LITRE

1003T **TRADEQUIP**
the trusted brand in equipment

Pump power: 240V/50Hz/0.5A
Pump output: 2.7-3.3 Litres per min.
Tank: 758L x 527W x 275Hmm
Minimum fluid capacity: 18 Litres
Maximum fluid capacity: 45 Litres
Size: 780L x 540W x 908Hmm



WARNING
Do Not use cleaning fluids with a flashpoint

Excludes GST
\$275
Inc. GST \$302.50

FEATURES

Sturdy metal construction and quality enamelled gloss finish.
Enclosed "High Volume" electric pump & fully screened pump housing.
Built-in replaceable pump inlet filter.
Chromed flexible metal fluid delivery pipe.
Large removable parts cleaning shelf for inspection and drying.
Immersion soaking when parts cleaning shelf removed.
Non welded one-piece tank with Quick Close fire safe lid mechanism.
Suitable for use with aqueous water based cleaning fluids.
Replacement parts available.

PARTS WASHER 180 LITRE

1004T **TRADEQUIP**
the trusted brand in equipment

Pump power: 240V/50Hz/0.5A
Pump output: 2.7-3.3 Litres per min.
Tank: 1135L x 545W x 320Hmm
Min. fluid capacity: 33 Litres
Max. fluid capacity: 90 Litres
Size: 1150L x 560W x 1430Hmm



WARNING
Do Not use cleaning fluids with a flashpoint

Excludes GST
\$455
Inc. GST \$500.50

FEATURES

Sturdy metal construction and quality enamelled gloss finish.
Enclosed "High Volume" electric pump & fully screened pump housing.
Built-in replaceable pump inlet filter.
Chromed flexible metal fluid delivery pipe.
Large removable parts cleaning shelf for inspection and drying.
Immersion soaking when parts cleaning shelf removed.
Non welded one-piece tank with Quick Close fire safe lid mechanism.
Suitable for use with aqueous water based cleaning fluids.
Replacement parts available.

PARTS WASHER BRUSH & HOSE

1806 **TRADEQUIP**
the trusted brand in equipment

Long life 70mm synthetic bristles
Polypropylene handle
Stepped hose fitting suitable for connecting to 13mm and 16mm spouts
Suits TradeQuip parts washers
1003T, 1004T & 1050



Stiff bristles are ideal for cleaning automotive and machined parts



Excludes GST
\$27
Inc. GST \$29.70

WARNING: ONLY SUITABLE FOR USE WITH WATER BASED SOLUTIONS

PARTS CLEANING CONCENTRATE

10 AND 20 LITRE

TRADEQUIP
the trusted brand in equipment



- ✓ ENVIRO FRIENDLY
- ✓ BIODEGRADABLE
- ✓ NON-TOXIC

FORMULATED FOR USE IN ALL TRADEQUIP PARTS CLEANERS

| Code | 5083T | 5082T |
|-----------------|-----------|------------|
| Bottle contents | 10 Litres | 20 Litres |
| Creates | 50 Litres | 100 Litres |
| Exl. GST | \$88 | \$139 |
| Incl. GST | \$96.80 | \$152.90 |



from
Excludes GST
\$88
Inc. GST \$96.80



REPLACEMENT PARTS WASHER PUMP

1005 **TRADEQUIP**
the trusted brand in equipment



Power: 230V 50Hz 26W 0.6Amp
Cable length: 305mm
Head max: 1.8m
Flowrate: 3.15 litres per minute
Outlet thread: 1/2" NPT Female
100L x 85H x 65W mm

WARNING: ONLY SUITABLE FOR USE WITH WATER BASED SOLUTIONS



Excludes GST
\$84
Inc. GST \$92.40

FEATURES

Sturdy poly/plastic body. Stainless steel shaft.
Suits parts washers with chromed flexible metal fluid delivery pipes.
Snap off inlet grill for easy cleaning.
Suitable for use with aqueous water based cleaning fluids.
Works with TradeQuip parts washers (Code/s 1003T, 1004T and 1050, sold separately)

DESIGNED FOR AUTOMOTIVE & INDUSTRIAL APPLICATION

ULTRASONIC PARTS CLEANERS

6 Litres **TRADEQUIP** *The trusted brand in equipment*

Capacity: 6 Litres
Ultrasonic power: 150W
Ultrasonic frequency: 40KHz
Heating power: 300W
Heating temperature: 20-80 C

Timer range: 0-30 Minutes
Tank material: 304 Grade 2mm thick
Tank size: 300L x 155W x 150Hmm
Size: 330L x 180W x 310Hmm

1036T

13 Litres **TRADEQUIP** *The trusted brand in equipment*

Capacity: 13 Litres
Ultrasonic power: 300W
Ultrasonic frequency: 40KHz
Heating power: 400W
Heating temperature: 20-80 C

Timer range: 0-30 Minutes
Tank material: 304 Grade 2mm thick
Tank size: 330L x 300W x 150Hmm
Size: 360L x 330W x 310Hmm

1037T



- * 30 Minute Timer
- * Adjustable Temp. Control
- * 304 Grade Stainless Steel Tank

Excludes GST
\$955
Inc. GST \$1050.50



Excludes GST
\$1599
Inc. GST \$1758.90



DON'T BE FOOLED BY CHEAPER IMITATIONS THAT ARE DESIGNED FOR DENTISTRY, MODEL BUILDING, OPTOMETRY & LIGHTER DUTIES

27 Litres **TRADEQUIP** *The trusted brand in equipment*

Capacity: 27 Litres
Ultrasonic power: 500W
Ultrasonic frequency: 40KHz
Heating power: 500W
Heating temperature: 20-80 C

Timer range: 0-30 Minutes
Tank material: 304 Grade 2mm thick
Tank size: 500L x 300W x 200Hmm
Size: 550L x 330W x 360Hmm

1038T

36 Litres **TRADEQUIP** *The trusted brand in equipment*

Capacity: 36 Litres
Ultrasonic power: 600W (adjustable)
Ultrasonic frequency: 28/40KHz
Heating power: 800W
Heating temperature: 20-80 C

Timer range: 0-30 Minutes
Tank material: 304 Grade 2mm thick
Tank size: 500L x 290W x 250Hmm
Size: 570L x 360W x 450Hmm

1039T



- * 30 Minute Timer
- * Adjustable Temp. Control
- * 304 Grade Stainless Steel Tank

Excludes GST
\$2119
Inc. GST \$2330.90



Excludes GST
\$3499
Inc. GST \$3848.90



FEATURES

TradeQuip "Made for the Trade" Ultrasonic Parts Cleaners make it easy to clean items like carbies, calipers, nuts & bolts, most small metal parts - even jewelry. Just fill the cleaner with water, mix with the appropriate ultrasonic cleaning additive (sold separately), set the timer and walk away to get on with another job. The ultrasonic cleaner works with or without heat and provides deep cleaning using ultrasound technology and water. The adjustable temperature and timer gives you a variety of cleaning performance options.



BLASTING MEDIA ABRASIVE

Tradequip "Made for the Trade" Blasting Media Abrasives are designed for use in conjunction with our Tradequip Mobile Blasting Kits and Blasting Cabinets. Abrasive blasting has been used for many years to clean and remove rust, paint and corrosion. There are many types of abrasive media available, the most common being Garnet, Steel Grit and Glass Bead. These media have an aggressive cut and can rapidly remove paint and rust. However, they can also generate significant heat, potentially resulting in warped metal and etched surfaces, and they cannot be used on fibreglass. Also, chrome, plastic, rubber, trim, and other parts must be removed from a work surface or masked-off before blasting. Alternatively, less-aggressive media, such as Walnut Shell, will do a great job at removing paint. Walnut Shell does not generate as much heat as other media, and can be used on sheet metal and fibreglass without damaging the base material. However, Walnut Shell as with any abrasive media, will require more clean-up as it leaves particles in the car body's seams and crevices that can be difficult to completely remove. Soda blasting media has non abrasive properties which makes it a very universal blasting media which can be applied to lighter materials such as aluminium, plastic, fibreglass, wood etc. Soda Blasting does not damage glass, rubber, chrome items if they are left on a vehicle for blasting.

GARNET 25KG MEDIUM 30/60 3020T

Garnet is a gemstone with excellent naturally abrasive properties. This hard abrasive is fast-cutting, low-dust producing and low-consuming, excellent for removing tough coatings, paint, rust and mill scale from steel. Garnet also permits precise feathering control. A good general outdoor surface preparation abrasive.



Excludes GST
\$58
Inc. GST \$63.800

GARNET 25KG FINE 35/100 3021T (Australian Mined)

Garnet is a gemstone with excellent naturally abrasive properties. This hard abrasive is fast-cutting, low-dust producing and low-consuming, excellent for removing tough coatings, paint, rust and mill scale from steel. Garnet also permits precise feathering control. A good general outdoor surface preparation abrasive.



Excludes GST
\$66
Inc. GST \$72.6050

WALNUT SHELLS 20KG 6-100 MICRON 3022T

Walnut Nut shells and other organic materials, don't cause anchor patterns, making them useful for removing dirt, grease, oil, carbon, scale, burrs and paint without changing the underlying substrate. Walnut shells can be an excellent choice for softer surfaces such as wood — they won't cause etching. Walnut shells are one of less abrasive blasting media you can use and are completely biodegradable, making them among the most environmentally-friendly blasting media.



Excludes GST
\$179
Inc. GST \$196.90

GARNET 25KG COARSE 20/40 3023T

Garnet is a gemstone with excellent naturally abrasive properties. This hard abrasive is fast-cutting, low-dust producing and low-consuming, excellent for removing tough coatings, paint, rust and mill scale from steel. Garnet also permits precise feathering control. A good general outdoor surface preparation abrasive.



Excludes GST
\$62
Inc. GST \$68.20

GLASS BEAD 25KG 106-300MICRON 3025T

Glass beads are used for general cleaning, peening and cosmetic finishing of sensitive metal surfaces; removing automotive paint; brightening grout and removing fungus and calcium deposits from tile; polishing cast iron, stainless steel, aluminium, propellers and turbine blades. Glass Beads are environmentally friendly and can be used in many blast applications to provide a finish with no profile. Use while working with metal, plastic or rubber materials to clean, debur and finish.



Excludes GST
\$99
Inc. GST \$108.90

SODA BI CARB 22KG 3028T (Product of America)

Clean tools, strip paint and more with Soda Bi-Carbonate. The medium-sized crystals provide blasting power to smooth and strip paint without damaging other surfaces. Works with aluminum, steel, stainless steel, fibreglass and more...



Excludes GST
\$135
Inc. GST \$148.50

SODA/SAND BLASTING HOOD



Durable fabric & synthetic-leather construction
Large 110mm x 55mm acrylic viewing plate
Adjustable internal helmet for added comfort
Reinforced side ventilation panels for increased airflow

FEATURES

Protect eyes and face from "rebounding" abrasive particles by wearing Abrasive Blasting Hood. Ideal for many abrasive-blasting applications.

Excludes GST
\$52
Inc. GST \$57.20



NOT FOR RESPIRATORY PROTECTION

BLASTING CABINET 220 LITRE CAPACITY



Includes gun and light

Cabinet capacity: 220 Litre
Working pressure: 60-110psi
Maximum media capacity: 20kg
4 Ceramic nozzle tips: 4, 5, 6 & 7mm
With gun & low voltage internal fluorescent light
Tempered glass view window: 250 x 525mm
External size: 1400H x 890L x 550Wmm



Tempered glass window
Side opening door

Suitable for use with workshop vacuum

220 LITRE Capacity

FEATURES

Freestanding floor model.
Complete with gun and low voltage internal fluorescent light.
Tempered glass viewing window with protective shields.
Cabinet fitted and ready to be used with a workshop vac as dust collection system.
Spare parts available in Australia.



Excludes GST
\$849
Inc. GST \$933.90

BLASTING CABINET 420 LITRE CAPACITY



Cabinet capacity: 420 Litre
Air regulator & gauge panel
4 Ceramic nozzles: 2x5mm, 2x6mm
Maximum media capacity: 70kg
Maximum air pressure: 125psi
Required air supply: 15-25CFM
14 gauge steel legs & 16 gauge panels
Sand blasting efficiency: 100cm²/min
Optimum operating pressure 60-110psi
External size: 1680H x 1180W x 940Dmm



Oversized hinged top door opening

420 LITRE Capacity



Includes blasting gun & vinyl blaster gloves

FEATURES

Perfect for surface preparation on any type where other forms of preparation are difficult.
Ideal for removing paint, rust, scale and oxidation.
Large viewing window gives the operator a wide viewing area.
Oversized hinged top door opening & large inside work area allows easy maneuverability.
Hinged door on hopper allows for easy abrasive changes.
Fluorescent light kit and 90CFM dust collector help the operator to maintain a good visual.
Rear-mounted dust collector.
Replaceable protective window.
Foot-pedal-controlled siphon blast gun.

Excludes GST
\$3099
Inc. GST \$3408.90



Foot operated pressure control valve

PORTA POWER KIT

2011T **TRADEQUIP**
The trusted brand in equipment

Safe working capacity: 10,000kg
9 Piece Kit

Set Includes

- 2,000kg Mini Ram - Compressed 139mm > Stroke 76mm
- 4,000kg Mini Ram - Compressed 42mm > Stroke 16mm
- 10,000kg Mini Ram - Compressed 118mm > Stroke 60mm
- 4,000kg Porta Power Ram - Compressed 276mm > Stroke 132mm
- 10,000kg Porta Power Ram - Compressed 350mm > Stroke 150mm
- 2,000kg Pull Back Ram - Extended 537mm > Stroke 128mm
- 5,000kg Pull Back Ram - Extended 613mm > Stroke 130mm
- 4 x Hooks - 2 Large and 2 Small
- Blow Mould Carry Case: 700 x 485 x 125mm

NEW

10,000kg Capacity

Excludes GST

\$499

Inc. GST \$548.90

TOO NEW TO PHOTOGRAPH

VISIT
WWW.TQBBrands.COM.AU
FOR UPDATED IMAGES AND MORE SPECS.



PORTA POWER KIT

2010T **TRADEQUIP**
The trusted brand in equipment

Safe working capacity: 10,000kg
14 Piece Kit containing pump and hose fittings

- Ram length retracted: 322mm
- Ram length extended: 452mm
- Extensions: 110,265,365,520mm
- Case: 905L x 385W x 175H mm
- Hydraulic hose length: 1500mm
- Hydraulic oil capacity: 650ml
- Adaptor diameter: 33mm
- Weight: 31kg



10,000kg Capacity

MADE FOR THE TRADE

FEATURES

- Spring loaded ram return system, allowing controlled retraction of the ram.
- Pump may be used in horizontal & vertical position.
- Constructed of high-grade steel and built to exacting standards for quality and durability.
- Lead-free paint finish is oil, grease and dirt-resistant.
- Pump has an automatic overload system.
- Easily adapts to hoses, rams, pumps, spreaders, and other accessories using common 1/4" fittings.

Excludes GST

\$465

Inc. GST \$511.50

PORTA POWER KIT

BPP20T **BORUM**
INDUSTRIAL WORKSHOP EQUIPMENT

- Safe working capacity: 20,000kg
- Extension tubes: 125, 255, 510, 700mm
- 3 each, 70mm connective tube & 60mm joint connector tube
- Base, Ram toe, Plunger toe
- Wedge toe, V-base, Wrench
- Retracted ram length: 285mm
- Ram stroke: 125mm
- Hydraulic hose length: 1470mm
- Weight: 62kg

20,000kg Capacity

INDUSTRIAL QUALITY



FEATURES

- Constructed of high-grade steel and built to exacting standards for quality and durability.
- Lead-free paint finish is oil, grease and dirt-resistant for easy cleanup.
- High quality hydraulic steel cylinder unit helps to reduce wear and extend service life.
- Piston-ram is treated and polished.
- Hydraulics are powered with a high quality oil, which offers better corrosion resistance and high/low temperature flexibility.
- Heavy walled extension tubes stand up in tough applications.



Excludes GST

\$1377

Inc. GST \$1514.70

COMBI PORTABLE BEAD BREAKER 5,000KG

BTBB05 **BORUM**
INDUSTRIAL WORKSHOP EQUIPMENT

- Working load limit: 5,000kg
- Pressure connection: 3/8"-18NPTF
- Rated pressure: 10,000psi
- Maximum rim size: 26"
- Suits 1,2 & 3 pce rims (up to 26") with pry bar / bead loosening pockets
- Ram stroke: 90mm

FEATURES

- Durable steel construction.
- Clamps to wheel rim & breaks bead simply with up to 5,000kg of force.
- Requires 10,000psi air/hydraulic pump (sold separately).

Excludes GST

\$629

Inc. GST \$691.90

Suits TradeQuip 2054T & 2054-H

INDUSTRIAL QUALITY



GIANT PORTABLE BEAD BREAKER 13,000KG

BTBB13 **BORUM**
INDUSTRIAL WORKSHOP EQUIPMENT

- Working load limit: 13,000kg
- Pressure connection: 3/8"-18NPTF
- Rated pressure: 10,000psi
- Maximum rim size: 26"
- Suits 5 pce rims 635-1,295mm (25"-51") with pry bar / bead loosening pockets
- Ram stroke: 105mm

FEATURES

- Economical solution for earthmover wheels 25" - 51" multi-piece rims with pry bar pockets.
- Hydraulically clamps on wheel.
- Durable steel construction.
- Hydraulic power breaks beads in seconds.
- Requires 10,000psi air/hydraulic pump (sold separately).

Suits TradeQuip 2054T & 2054-H

Excludes GST

\$799

Inc. GST \$878.90



INDUSTRIAL QUALITY

AIR/HYDRAULIC PUMP

2054T **TRADEQUIP**
The trusted brand in equipment

- Maximum output pressure: 10,000psi
- Usable hydraulic fluid capacity: 2.25 Litres
- Operating air pressure: 90-145 psi
- Air consumption: 7.5CFM @ 100 psi
- Oil delivery with No Load: 49.5 cu.in./min
- Oil delivery with Load: 7.6 cu.in./min
- Input (Air) port thread: 1/4" -18 NPT
- Output (Oil) port thread: 3/8" -18 NPT

HANDS FREE POWER

MADE FOR THE TRADE

FEATURES

- Durable light-weight corrosion-free aluminium.
- Built-in overload system prevents pump from being used beyond its safety capacity.
- Ergonomic hand/foot activation lever.
- Air/oil filters minimise contaminants in hydraulic system.
- Perfect for porta power rams & bead breakers.
- Compact design fits in truck storage boxes.
- Air exhaust muffler for quiet operation.



Excludes GST

\$699

Inc. GST \$768.90

SELF-EVACUATING OIL DRAINER 65 LITRE

1046T **TRADEQUIP**
The trusted brand in equipment

Capacity: 65 Litres
Working height: 1080-1600mm
Discharge pressure: 12psi
Telescopic adjustment
Air inlet: 1/4" BSP

Excludes GST
\$413
Inc. GST \$454.30

MADE FOR THE TRADE

TELESCOPIC
COLLECT
STORE/CARRY
DISCHARGE

Fluid sight tube

Telescopic height adjustment

Air pressure relief valve



AIR OPERATED

FEATURES

Collect, transfer, evacuate used engine oils, transmission fluids, power steering fluids etc. Top quality heavy-gauge steel collection tank with adjustable telescopic drain pan. Offset drain bowl and Tank oil level indicator. Air pressure relief valve prevents. Sturdy rubber front wheels and ball bearing-mounted rear castors provide stability and easy maneuverability. Lead-free paint is oil, grease and dirt-resistant. Oil, heat, ozone and abrasion resistant hose.

OIL DRAIN PLUG KEY SET

9027T **TRADEQUIP**
The trusted brand in equipment

Hex Key socket bits: 8mm, 9mm, 10mm, 12mm, 13mm, 14mm and 17mm
Square socket bits: 5/16", 3/8", 7mm, 8mm, 10mm, 11mm, 12mm, 13mm & 14mm
Torx socket bits: T45
Spline (tamper) socket bits: M16
Triangular socket bits: 10mm
Square Drive socket: 10mm
1 x 3/8" Drive Sliding T-Handle

Excludes GST
\$88
Inc. GST \$96.80

MADE FOR THE TRADE



CHROME VANADIUM STEEL

TRUCK FLUID DRAIN PAN WITH HAND PUMP 65 LITRE

1147T **TRADEQUIP**
The trusted brand in equipment

Lightweight high-impact polypropylene.
Oil and coolant resistant
Manoeuvrable 4" castors
Tank size: 1300x730x200mm

Excludes GST
\$579
Inc. GST \$636.90

MADE FOR THE TRADE

FEATURES

Lightweight high-impact polypropylene. Suitable for engine oil, coolant and transmission fluid. Built-in rotary hand discharge pump. Removable metal filter screen. Smooth rolling rubber castor wheels.



LIGHT WEIGHT POLYMER

Built-in rotary hand discharge pump



Removable metal filter screen



65 LITRE Capacity

TRUCK FLUID DRAIN PAN 60 LITRE

1146T **TRADEQUIP**
The trusted brand in equipment

Capacity: 60 Litres
Enamel steel construction
Oil and coolant resistant
Size: 1174 x 641 x 673mm
Front swivel castors

MADE FOR THE TRADE

FEATURES

Enamelled steel construction. Oil and coolant resistant. Removable metal screen. Two front swivel castors. Two rear fixed wheels. Brass drain valve. Transfer pump coupling. Grab handle.

60 LITRE Capacity

Excludes GST
\$285
Inc. GST \$313.50

Removable metal filter screen



TRUCK FLUID DRAIN PAN 95 LITRE

1145T **TRADEQUIP**
The trusted brand in equipment

Capacity: 95 Litres
Minimum tray clearance: 196mm
Reservoir dimensions: 910L x 725W x 165Hmm
Size: 1120L x 780W x 195Hmm

Handle can also be mounted here

NEW

FEATURES

Enamelled steel construction. Oil and coolant resistant. Removable metal screen. Four swivel wheels, two which are braked. Handle can be mounted to front or side. Drain valve & Grab handle.

95 LITRE Capacity

Excludes GST
\$389
Inc. GST \$427.90

Removable metal filter screen



*Additional Freight Rates may apply

MOTORCYCLE LIFTERS

MOTORCYCLE LIFTER 450KG

2101T **TRADEQUIP**
The trusted brand in equipment

Safe working capacity: 450kg
Height: 175 - 750mm
Platform: 680W x 2200Lmm
Weight: 120kg

MADE FOR THE TRADE

Excludes GST
\$1189
Inc. GST \$1307.90



450kg Capacity

FEATURES
Ideal lift for use with motorcycles, ATV's, tractors, personal watercraft & snowmobiles. Locking bar for safety. Powder coated structural heavy duty steel. Extra Long Full width loading ramp. Step-less rate of lowering irrespective of load. Oil trap plate for easy drainage. 2 foot pedals for raising & lowering - for easy hands free operation. Fitted with 2 position platform locking device to prevent accidental lowering. Quality wheels and swivel castors making it easier to position and move around. Lockdown bolts to prevent unwanted movement during use. Does not include tie down straps.

OPTIONAL EXTRA
To perform a Full Wheel Service add the TradeQuip 2104T Scissor Lift

MOTORCYCLE LIFTER AIR ACTUATED 680KG

2103T **TRADEQUIP**
The trusted brand in equipment

Safe working capacity: 680kg
Height: 185 - 825mm
Platform dimensions: 710 x 2000mm
Required air pressure: 0.75-0.85Mpa
Weight: 169kg

Excludes GST
\$2099
Inc. GST \$2308.90

MADE FOR THE TRADE

680kg Capacity



OPTIONAL EXTRA Side Extensions
2103T-EXT

FEATURES
Designed to deliver the ideal lift for use with motorcycles, ATV's, tractors, personal watercraft, and snowmobiles. Locking bar for safety. Extra long full width loading ramp. Powdercoated structural heavy duty steel. Stepless rate of lowering irrespective of the load. Oil trap plate for easy drainage. Lockdown bolts. 2 foot pedals for raising & lowering - for easy hands free operation. Fitted with 2 position platform locking device.

OPTIONAL EXTRA
To perform a Full Wheel Service add the TradeQuip 2104T Scissor Lift

MOTORCYCLE LIFTER 360KG

2102T **TRADEQUIP**
The trusted brand in equipment

Safe working capacity: 360kg
Height: 205 - 780mm
Platform: 490W x 1345Lmm
Weight: 95kg

MADE FOR THE TRADE

Excludes GST
\$929
Inc. GST \$1021.90



360kg Capacity

Features wide lifting stability

OPTIONAL EXTRA
To perform a Full Wheel Service add the TradeQuip 2104T Scissor Lift

MOTORCYCLE SCISSOR LIFT 500KG

2104T **TRADEQUIP**
The trusted brand in equipment

Safe working capacity: 500kg
Height: 95 - 420mm
Platform dimensions: 450x150mm
Weight: 13.8kg

MADE FOR THE TRADE

500kg Capacity



FEATURES
Designed to deliver the ideal lift for use with motorcycles, ATV's, tractors, personal watercraft, and snowmobiles. Lifts back wheel off lift table for tyre/wheel change. Powder coated structural heavy duty steel construction. Rotate lead screw to adjust & raise the lift. Bolt down lugs to prevent unwanted movement.

Excludes GST
\$165
Inc. GST \$181.50

PORTABLE EVAPORATIVE COOLER 750W

1029T **TRADEQUIP**
The trusted brand in equipment

240V/50Hz/750W 3 speed motor
Max. air flow: 23,000 m3 per hour
Water consumption: 20-35 litres per hour
Effective cooling area: 200-260sqm
Cooling area: 200-260m2
Water tank capacity: 200 Litres
1800H x 1600W x 780Dmm
Weight: 128kg

MADE FOR THE TRADE

Excludes GST
\$4899
Inc. GST \$5388.90

*Freight Rates May Apply



Nylon Castors for easy portability



Remote Control Timer Panel

TRADEQUIP EVAPORATIVE COOLERS FEATURES & BENEFITS

Moulded polyethylene housing will not crack and is rust & leak proof.
Environmentally-friendly alternative to traditional reverse cycle A/C.
Cools without chemicals or refrigerants.
Long-term dependability. Near maintenance free operation.
Cools where traditional cooling methods are impractical or cost-prohibitive.
Remote control speed adjustment. Direct drive. LCD 24 hour timer panel.
Easy to read water level sight tube gauge.
Dual pour in refill water inlet and/or 3/4" hose fitting for automatic tap refill.
Adjustable water flow & drain valve. Nylon castors for easy portability.



YouTube
Product Demonstration online

750 Watts



VIEW RANGE HERE

PORTABLE EVAPORATIVE COOLER 550W

1027T **TRADEQUIP**
The trusted brand in equipment

240V/50Hz/550W 3 speed motor
Max. air flow: 18,000 m3 per hour
Effective cooling area: 100-150sqm
Water consumption: 12-18 litres per hour
Water tank capacity: 100 Litres
1510H x 1120W x 680Dmm
Weight: 58kg

EUROPEAN DESIGN SYNCHRONOUS SWING FUNCTION

MADE FOR THE TRADE



Remote Control Timer Panel

550 Watts



Cooler Maintenance

Excludes GST
\$1399
Inc. GST \$1538.90

*Freight Rates May Apply



Remote Control Timer Panel

750 Watts



Cooler Maintenance

MADE FOR THE TRADE

Excludes GST
\$1699
Inc. GST \$1868.90

*Freight Rates May Apply

COOLER COVER

1035T-CO **TRADEQUIP**
The trusted brand in equipment

Water-resistant fabric
Lightweight and breathable
UV treated and Easy to use
To protect 1027T, 1028T and 1035T TradeQuip Portable Evaporative Coolers when not in use.

MADE FOR THE TRADE

Excludes GST
\$99
Inc. GST \$108.90



INDUSTRIAL PEDESTAL MISTING FAN 650mm

1182T **TRADEQUIP**
The trusted brand in equipment.

240V/50Hz/230W 3 speed motor
90° Oscillation
Water shortage protection.
Drop the temperature: 2-8°C
Adjustable mist-Exit Vol: 0-16KG/Hr
Effective spray distance: 8-10mtr
Suitable for cooling people, stockbreeding or greenhouse applications.

Excludes GST
\$599
Inc. GST \$658.90

MADE FOR THE TRADE

FEATURES
Great for workshops and factory floor areas.
Adjustable height to 1.8m and 3 speed operation.
Large water storage tank & integrated water reservoir.
No mess drip water collector.
Heavy duty base for safety and stability.
Low pressure water pump for reliability and longevity.
Automatic shut-off when water tank is empty.



230 Watts

PORTABLE INDUSTRIAL SPOT COOLING AIR CONDITIONERS

TRADEQUIP
The trusted brand in equipment.

MADE FOR THE TRADE

from
Excludes GST
\$1379
Inc. GST \$1516.90



950 Watts

2000 Watts

3000 Watts

2.7KW

4.5KW

6.5KW

INDUSTRIAL CABLE REEL 15 METRE

1994T **TRADEQUIP**
The trusted brand in equipment.

10 Amp

MADE FOR THE TRADE

Excludes GST
\$219
Inc. GST \$240.90



Great Accessory Option

AUTO REWIND

| Code | 1031T | 1032T | 1033T |
|--------------------|------------------|------------------|------------------|
| Power Unit | 240V 50Hz | 240V 50Hz | 240V 50Hz |
| Rated Power | 950W | 2000W | 3000W |
| Mains Plug | 10 Amp | 15 Amp | 15 Amp |
| Cooling Capacity | 2.7KW/9200Btu | 4.5KW/15300Btu | 6.5KW/22200Btu |
| Max. Air Flow | 400m3 p/hr | 800m3 p/hr | 1200m3 p/hr |
| Noise Level | 55dB(A) | 60dB(A) | 65dB(A) |
| Operating Temp. | 18° - 45° C | 18° - 45° C | 18° - 45° C |
| Suction Pressure | 2.5Mpa (Max.) | 2.5Mpa (Max.) | 2.5Mpa (Max.) |
| Discharge Pressure | 4.5Mpa (Max.) | 4.5Mpa (Max.) | 4.5Mpa (Max.) |
| Refrigerant | R410a/460g | R410a/800g | R410a/1050g |
| Dimensions | 855Hx430Wx405D | 1035Hx520Wx480D | 1245Hx640Wx560D |
| Excl. GST | \$1379 | \$2649 | \$3949 |
| Incl. GST | \$1516.90 | \$2913.90 | \$4343.90 |

INDUSTRIAL VENTILATION FANS

TRADEQUIP
The trusted brand in equipment.

MADE FOR THE TRADE

| Code | 1025 | 1056 | 1141T |
|------------------|-----------------|-----------------|-----------------|
| Fan Diameter | 300mm | 400mm | 450mm |
| Voltage | 240V 50Hz | 240V 50Hz | 240V 50Hz |
| Power | 520W | 1100W | 1700W |
| Speed | 2800rpm | 2800rpm | 2800rpm |
| Noise Level | 92db2 (A) | 92db2 (A) | 92db2 (A) |
| Air Delivery | 60m3per minute | 96m3per minute | 162m3per minute |
| Static Pressure | 343Pa | 700Pa | 972Pa |
| Excl. GST | \$295 | \$735 | \$869 |
| Incl. GST | \$324.50 | \$808.50 | \$955.90 |

FEATURES
These TradeQuip "Made for the Trade" Industrial Ventilator Fans air out rooms, circulate air or dry wet areas with a powerful air output of 60m³ per minute. Features include an ergonomic handle for effortless transport and an aluminium blade with steel housing construction for long lasting durable performance. Complete with 5 metre flexible ducting.

WARNING: NOT INTENDED FOR DUST EXTRACTION

from
Excludes GST
\$295
Inc. GST \$324.50

ALLOY MULTI-BLADE FANS



300mm

400mm

450mm

Also available separately
5m Flexible Ducting
300, 400 & 450mm diameter
10m Flexible Ducting
300mm diameter only

**INDUSTRIAL
QUALITY**



3/4HP PEDESTAL DRILL PRESS 16 SPEED

CH16NFT **BORUM**
INDUSTRIAL WORKSHOP EQUIPMENT

Motor: 240Volt 3/4HP
Number of speeds: 16
Spindle taper: MT2
Spindle speeds: 162-3000rpm
Max. drilling capacity: 16mm
Max. spindle stroke: 78mm
Max. distance spindle to table: 7810mm
Max. distance spindle to base: 1219mm
Chuck: 16mm
Swing: 535
Size of table: 473x410mm
Diameter of column: 73mm
Size of base: 450x265mm
Overall height: 1588mm

**Max.
DRILL
CAPACITY
16mm**

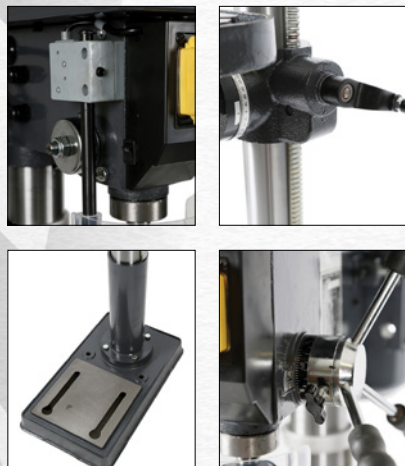

Excludes GST
\$1059
Inc. GST \$1164.90



Overall height: 1588mm

1HP PEDESTAL DRILL PRESS 16 SPEED

CH18FT **BORUM**
INDUSTRIAL WORKSHOP EQUIPMENT

Motor: 240Volt 1HP
Number of speeds: 16
Spindle taper: MT2
Spindle speeds: 200-3160rpm
Max. drilling capacity: 20mm
Max. spindle stroke: 82mm
Max. distance spindle to table: 775mm
Max. distance spindle to base: 1270mm
Chuck: 16mm
Swing: 430mm
Table diameter: 350mm
Diameter of column: 80mm
Size of base: 460x270mm
Overall height: 1625mm

**Max.
DRILL
CAPACITY
20mm**



Overall height: 1625mm

Excludes GST
\$1529
Inc. GST \$1681.90



The same reliable
*'Heavy Duty Industrial
Quality Drill Presses'*
since we started
manufacturing them in
1984... but with
the benefit of some
*21st Century
features*

ALL BORUM DRILL PRESSES FEATURE

Flexible worklight. Engineering style work table.
Oversize micro-switch activated safety guard.
Low-noise belt drive with cast iron balanced pulleys.
Safety ON-OFF switch fitted with a dust cover and positive action push buttons plus a large (Red) self locking "Emergency Stop" hinge cover.
Precision spindle bearing for long life & high accuracy.
Table control via hand crank and gear rack with high load capacity.
Long quill stroke, easy to adjust depth stop at the capstan handle.
Thick-walled, precision-ground column for extra rigidity.
Powerful long-life commercial drive motor provides high reliability.
Ground set-up areas on table and base plate.
Solid rotating work table with diagonal clamping slots.



Scan code to go to our Top Tips guides and learn how to extend the life of your TQB Brands equipment

Visit our webpage
www.tqbbrands.com.au
for instructional & pre-start videos.

PRODUCT SUPPORT

Go to our TQB Brands Website for extensive product support & regular information updates.

For a comprehensive guide to your TQB Brands product Maintenance, Setup and Demonstration



YouTube
Scan code to go to TQB Brands Youtube Channel

AIR/HYDRAULIC BOTTLE JACK BLEED PROCEDURE



A Step by Step Guide To Bleeding TQB Brands Series Air/Hydraulic Bottle Jacks. **3:17**

Air/Hydraulic Bottle Jack Bleeding Video

12K views • 1 year ago



Hydraulic Bottle Jack Bleeding Video

17K views • 1 year ago



TradeQuip Diesel/Kerosene Workshop Heaters

5K views • 3 years ago



TradeQuip 2020 Evaporative Cooler Range

2.7K views • 1 year ago

TROUBLESHOOTING DOCUMENTS

- DRILLING MACHINES (0)
- ENGINE STANDS & SUPPORTS (0)
- FANS, COOLERS, HEATERS & AIRCON (6)
- GARAGE JACKS (25)
- MOTORCYCLE LIFTERS (0)
- OIL DRAINERS & PUMPS (0)
- PARTS WASHERS (2)
- PORTA POWERS & PANEL REPAIR (1)
- PRESSES & PIPE BENDERS (17)
- STANDS, RAMPS & DOLLIES (1)
- TRANSMISSION JACKS (17)
- TROLLEYS & CREEPERS (0)
- WHEEL & SUSPENSION TOOLS (0)



Scan code to go to TQB Brands Troubleshooting Documents

Top Tips Product Information



Scan code to go to our Top Tips guides and learn how to extend the life of your TQB Brands equipment

Visit our webpage www.tqbbrands.com.au for instructional & pre-start videos.



WORKSHOP HEATER 30kW

1096T **TRADEQUIP**
the trusted brand in equipment

Power output: 30kW - 102,360 Btu/h
Motor: 240V/50Hz 10A 230W
Air delivery: 720cubic metres per hour
Noise level: 76dB(A)
Fuel consumption: 2.4kg/hr
Tank capacity: 38 Litres
Dimensions: 880 x 456 x 590mm
Weight: 21kg

MADE FOR THE TRADE

**RUNS UP TO 9 HOURS
ON A SINGLE FILL**

FEATURES

Burns diesel or kerosene. Built in oil burner.
Electronic flame control system.
Safety overheat thermostat and pressure switch.
Stainless steel heat exchanger.
Double skinned combustion chamber for thermo-acoustic insulation and safe low surface temperature.
Preheated oil filter. Twist lock fuel cap with cable.
Pre-purge and post-ventilation cycles.



Scan code for
online product
demonstration

SEASONAL LINE



**VERY
Limited
Stock**

TRADEQUIP
the trusted brand in equipment

Excludes GST
\$719
Inc. GST \$790.90



WORKSHOP HEATER 50kW

1097T **TRADEQUIP**
the trusted brand in equipment

Power output: 50kW - 170,600 Btu/h
Motor: 240V/50Hz 10A 340W
Air delivery: 1100 cubic metres per hour
Noise level: 77dB(A)
Fuel consumption: 4kg per hour
Tank capacity: 56 Litres
Dimensions: 1090 x 490 x 585mm
Weight: 27kg

MADE FOR THE TRADE

**RUNS UP TO 9 HOURS
ON A SINGLE FILL**

FEATURES

Burns diesel or kerosene. Built in oil burner.
Electronic flame control system.
Safety overheat thermostat and pressure switch.
Stainless steel heat exchanger.
Double skinned combustion chamber for thermo-acoustic insulation and safe low surface temperature.
Preheated oil filter. Twist lock fuel cap with cable.
Pre-purge and post-ventilation cycles.

SEASONAL LINE



**VERY
Limited
Stock**

TRADEQUIP
the trusted brand in equipment

Excludes GST
\$819
Inc. GST \$900.90