

# Owners Manual

Product Code: 1055T

**MADE FOR THE  
TRADE**

**TQ TRADEQUIP**  
the trusted brand in equipment

**WHEEL/TYRE  
LIFTER**



#### Specifications

- Safe Working Capacity: 50kg
- Lift Range from Roller Top to Ground: 93 ~ 1078mm
- Roller Diameter & Length: (D) 76.2 x 240mm
- Rollers Moving Distance: 125mm
- Rollers Push Force: <4kg based on 50kg load
- Lifting Handle Force: 1kg based on 50kg load
- Front Castors: 2(D) 75 x 24mm
- Rear Castor - Locking: 2(D) 75 x 24mm
- Base: 876(L) x 720(W) x 101.6(H)mm
- Weight: 51.25kg

#### About the TradeQuip brand

The 'TradeQuip' brand of workshop equipment, is designed for use in a demanding workshop environment by professional users. With proven and trusted "Made for the Trade" reliability, 'TradeQuip' branded products offer the very best in performance for an affordable price. All backed by a 1year trade guarantee across 1,000+ distributors Australia wide.

**TQ TRADEQUIP**  
the trusted brand in equipment

**TQPRO**  
Trusted by various professionals

**BORUM**  
INDUSTRIAL WORKSHOP EQUIPMENT

**WARNING INFORMATION**

**IMPORTANT: READ ALL INSTRUCTIONS BEFORE USE**



**WARNING**

The instructions and warnings contained in this manual should be read and understood before using or operating this equipment. Do not allow anyone to use or operate this equipment until they have read this manual and have developed a thorough understanding of how this equipment works. Failure to observe any of the instructions contained in the manual could result in severe personal injury to the user or bystanders, or cause damage to the equipment and property. Keep this manual in a convenient and safe place for future reference.

Whilst every effort has been made to ensure accuracy of information contained in this manual, the TQB Brands Pty Ltd policy of continuous improvement determines the right to make modifications without prior warning.

**CONTENT**

**WARNING INFORMATION ..... 2**

**CONTENT ..... 2**

**STANDARD OPERATING PROCEDURE ..... 3**

**ASSEMBLY, OPERATION, PREVENTITIVE MAINTENANCE..... 4**

**PARTS LIST & DIAGRAM..... 7**

**PRODUCT INFORMATION TOP TIPS..... 8**

**WARRANTY ..... 9**

## STANDARD OPERATING PROCEDURE

**DO NOT** use this machine unless you have been trained and assessed to a competent level in its safe use and operation, and have been given permission to use this

	Safety glasses must be worn when operating this equipment		Long loose hair must be contained when operating this equipment
	Safety footwear must be worn when operating this equipment		Close fitting/protective clothing must be worn when operating this equipment
	Rings and jewellery must not be worn when operating this equipment		DO NOT tilt the unit

### PRE-OPERATIONAL SAFETY CHECKS

- Before using the wheel/tyre ensure it is in sound condition, and good working order.
- Replace or repair damaged parts. Use recommended parts only. Non authorised parts may be dangerous and will invalidate the warranty. The nuts and bolts supplied with the crane are all high strength and should not be substituted for inferior types.
- The use of portable automotive lifting devices are subject to certain hazards that cannot be prevented by mechanical means, but only by the exercise of intelligence, care and common sense. It is therefore essential to have owners and personnel involved in the use and operation of the equipment who are careful, competent, trained and qualified in the safe operation of the equipment and its proper use. Examples of hazards are dropping, tipping, or slipping of loads caused primarily by improperly securing loads, overloading, off-centred loads use on other than hard level surfaces and using equipment for a purpose for which it was not designed.
- Read, study, understand & follow all instructions before using.
- DO NOT use (or modify) this product for any other purpose than that for which it was designed without consulting the manufacturer's authorized representative.
- DO NOT use with tandem and duplex wheel and tyre combinations.
- Inspect the Tyre/Wheel Lifter before each use.
- DO NOT use if damaged, altered, modified, in poor condition or unstable due to loose or missing components. Make corrections before using.
- User and bystanders must wear eye protection.
- DO NOT exceed rated capacity.
- Use only on a hard, level, dry concrete surface free from expansion joints and all obstructions.
- DO NOT use with tyres that are wider than 12".
- Before moving a load, secure the wheel/tyre assembly to the lift arm with the tyre restraint mechanism provided (tyre hold).
- Lower load all the way before transporting.
- DO NOT start the vehicle's engine or drive the vehicle when removing or installing wheel/tyre combinations with a Wheel/Tyre Lifter.
- Stay clear of lifted load.
- When transporting a load, be sure not to make any sudden or abrupt stops as this may cause the telescopic lift arm assembly to extend.
- Failure to heed these warnings may result in serious or fatal personal injury and/or property damage.

### INTENDED USE

For the lifting, lowering, supporting and transporting of tyre and rim assemblies up to 50kgs and 300mm wide

**ASSEMBLY, OPERATION, PREVENTITIVE MAINTENANCE****1. FEATURES**

The *TradeQuip "Made for the Trade"* Wheel/Tyre Lifter is characterized by a pair of laterally spaced lifting arms that raise and lower in unison and are so, arranged as to contact the vehicle tyre at two areas on its circumference to raise or lower a wheel/tyre combination for the purpose of removing, transporting, and replacing wheel and tyre combinations. The lifter's drive screw can be activated by an air or battery-operated impact gun from the top of the unit in a vertical position or through a gear box in a horizontal position if installed. The intent of the lifter is to remove risk of back or other injury to technicians.

**2. ASSEMBLY**

**PLEASE REFER TO THE EXPLODED VIEW DRAWING IN THIS MANUAL IN ORDER TO IDENTIFY PARTS.**

1. Activate the locks on the locking caster wheels so the lifter will not move during the assembly procedures.
2. The lifter can be activated directly from the top of the (#5) main upright assembly or the (#1) -optional gear box assembly can be attached to the top of the (#5) main upright assembly with the four (#2) screws, (#3) lock washers and (#4) washers, in order to operate the lifter from the side.
3. Assemble the (#5) main upright assembly to the (#21) base frame with the (#6) screws, (#18) lock washers and (#19) washers as shown in the drawing. Do not tighten hardware at this time.
4. Attach one end of the (#11) main steering handle to the (#5) main upright assembly and the other end of the main steering handle to the (#21) base frame with the (#12) screws, (#3) lock washers and (#4) washers. Do not tighten hardware at this time.
5. Tighten hardware mentioned in step 2 first and then tighten hardware mentioned in step 3.
6. Fit the (#15) lift arm assembly over the top of the (#5) main upright assembly and (#11) main steering handle. Continue to lower the lift arm assembly until its mounting pad holes align with the holes in the raising/lowering pad on the front of the (#5) main upright assembly. Secure the two assemblies together with the (#17) screws, (#18) lock washers and (#19) washers provided.
7. Secure the (#14) socket for tyre hold to the (#15) lift arm assembly with the three (#16) screws, (#18) lock washers and (#19) washers as shown in the exploded view drawing.
8. Slide the (#10) tyre hold upright in the (#14) socket for tyre hold and secure them together by threading the (#9) knob in the socket for tyre hold until tight. Slide the (#13) tyre hold in the (#10) tyre hold upright and secure them together by threading the (#9) knob in the tyre hold upright until tight.
9. Secure the (#8) handle and (#7) tool tray to the (#5) main upright assembly as shown in the exploded view drawing.

**3. BEFORE USE**

Prior to each use conduct a visual inspection by checking for abnormal conditions, such as cracked joints and damaged, loose, or missing parts.

The owner and or user must have an understanding of the manufacturers operating instructions and warnings before using this product. Personnel involved in the use and operation of equipment shall be careful, competent, trained and qualified in the safe operation of the equipment and its proper use when servicing motor vehicles and their components. Warning information should be emphasised and understood. If the operator is not fluent in English, the manufacturer's instructions and warnings shall be

read to and discussed with the operator in the operator's native language by the purchaser/owner making sure that the operator comprehends its contents.

Owner and or user must study and maintain for future reference these manufacturer's instructions. Owner and or user is responsible for ensuring all warning labels and instruction manuals remain legible and intact. Replacement labels and literature are available from the manufacturer.

## 4. OPERATION

**PLEASE REFER TO THE EXPLODED VIEW DRAWING IN THIS MANUAL IN ORDER TO IDENTIFY PARTS.**

### Removing a Wheel/Tyre Assembly

1. Raising and lowering of the lifter is accomplished by engaging the ½" drive tool with the ½" drive socket at the top of the (#5) main upright assembly or the side of the #1 gear box assembly if installed. The drive tool can be a ½" air impact gun or ½" rechargeable impact gun. Operating the drive tool in a clockwise direction will raise the (#15) lift arm assembly and operating in reverse will lower the lift arms.
2. Raise the vehicle to the desired work height and ensure the vehicle is secured.
3. Make sure the wheel/tyre combination to be removed will clear the vehicle lift and remove the lug nuts.
4. Push the lifter in towards the wheel/tyre combination and raise the (#15) lift arm assembly so the lift arms straddle the tyre. It may be necessary to extend the telescopic portion of the (#15) lift arm assembly so the side wall of the tyre comes in contact with the rear of the lift arm offset. Raise the (#15) lift arm assembly so its individual lift arm rollers contact with the tyre.
5. Secure the wheel/tyre combination to the lift arms with the (#13) tyre hold. This can be accomplished by loosening the (#9) knobs on the (#14) socket for tyre hold and (#10) tyre hold upright. Loosening the knobs will enable the (#10) tyre hold upright to extend to a height necessary for the (#13) tyre hold to clear the tyre and then extend the (#13) tyre hold so it is positioned and makes contact with the centre of the tyre. Once adjustments are made, tighten the knob on the (#10) tyre hold upright. Now push down on the (#13) tyre hold while tightening the knob on the (#14) socket for tyre hold.
6. Retract the telescopic portion of the (#15) lift arm assembly if it has been extended and slowly pull the lifter away from the wheel drum making sure the wheel/tyre combination clear the drum and the vehicle lift.
7. Prior to transporting the loaded lifter from one place to another, always lower the lift arms all the way down to prevent loss of load.

### IMPORTANT:

The telescopic lift arm feature is designed to extend and retract the lift arm assembly with very little effort. When transporting a loaded lifter, be sure not to make any sudden or abrupt stops as this may cause the telescopic portion of the (#15) lift arm assembly to unintentionally extend.

### Installing a Wheel/Tyre Assembly

1. Push the lifter in towards the wheel/tyre combination so the side wall of the tyre comes in contact with the rear of the lift arm offset. Raise the (#15) lift arm assembly so the individual lift arm rollers make contact with the tyre.
2. Secure the wheel/tyre combination to the lift arms according to step 5 of the Removing Wheel/Tyre Assembly section.
3. Prior to transporting the loaded lifter from one place to another, always lower the lift arm assembly all the way down to prevent loss of load.
4. Position the lifter in front of the vehicle's wheel drum and raise the lifter's arms so the wheel/tyre combination will line up with the wheel drum. Move the lifter in towards the wheel drum while at the same time making sure the wheel/tyre combination is at the proper height to clear the vehicle lift. It may be necessary to extend the telescopic portion of the (#15) lift arm assembly so the wheel can fit flush against the wheel drum.
5. Disengage the tyre hold mechanism from the tyre so the tyre can be rotated for alignment of the wheel mounting holes with the wheel drum studs.
6. Secure the wheel/tyre combination to the wheel drum with lug nuts and tighten according to the required torque and in the proper rotation.
7. Retract the telescopic portion of the (#15) lift arm assembly if necessary and back the lifter away from the vehicle and vehicle lift.

### LUBRICATION

A general-purpose lithium base grease must be used in the two grease fittings located on top of the lift arm assembly and one on top of the gear box assembly if installed. A white lithium spray grease can be used in the bearing portions of the caster wheel assemblies. Usage and shop conditions determine the frequency of lubrication. The Lifter should be lubricated no less than once every three-month period.

## 5. STORAGE

This TradeQuip wheel/tyre lifter should always be stored under cover in a dry location and on a level surface.

## 6. MAINTENANCE

Replace or repair damaged parts. Use recommended TradeQuip genuine parts only. Non authorised parts may be dangerous and will invalidate the warranty.

- Always store the Lifter in a well-protected area where it will not be exposed to inclement weather, corrosive vapours, abrasive dust, or any other harmful elements. The Lifter must be cleaned of water, snow, sand, mud, grit, oil, grease, or other foreign matter before and after using.
- Inspect the Lifter before each use. Do not use the Lifter if any component is cracked, broken, bent, or shows signs of damage. Do not use the Lifter if it has loose or missing hardware or components or is modified in any way. Take corrective action before using the Lifter again.

## 7. SERVICE & REPAIR

Any wheel/tyre lifter found damaged in any way or found to be worn or operates abnormally should be removed from service until repaired by an authorised service agent. Owners and / or operators should be aware that repair of this product may require specialised equipment and knowledge. Only authorised parts, labels and decals shall be used on this equipment.

## PARTS LIST &amp; DIAGRAM

Part #	Description	QTY	Part #	Description	QTY
1	Gear Box Assembly (optional-not included)	1	14	Socket for Tyre hold	1
2*	Screw (M8x25) (optional-not included)	4	15	Lift Arm Assembly	1
3*	Lock Washer (8)	13	16	Screw (M10x20)	3
4*	Washer (8)	13	17	Screw (M10x35)	4
5	Main Upright Assembly	1	18	Lock Washer (10)	11
6	Screw (M10x25)	4	19	Washer (10)	11
7	Tool Tray	1	20	Locking Castor	2
8	Handle	1	21	Base Frame with Castors Installed	1
9	Knob	2	22	Castor	2
10	Tyre Hold Upright	1	Not Shown		
11	Main Steering Handle	1	Hardware Kit (included #2(4), #3(4) #4(4))		1
12	Screw (M8x16)	9	Not Shown		
13	Tyre Hold	1	Product/Warning Label Kit		1

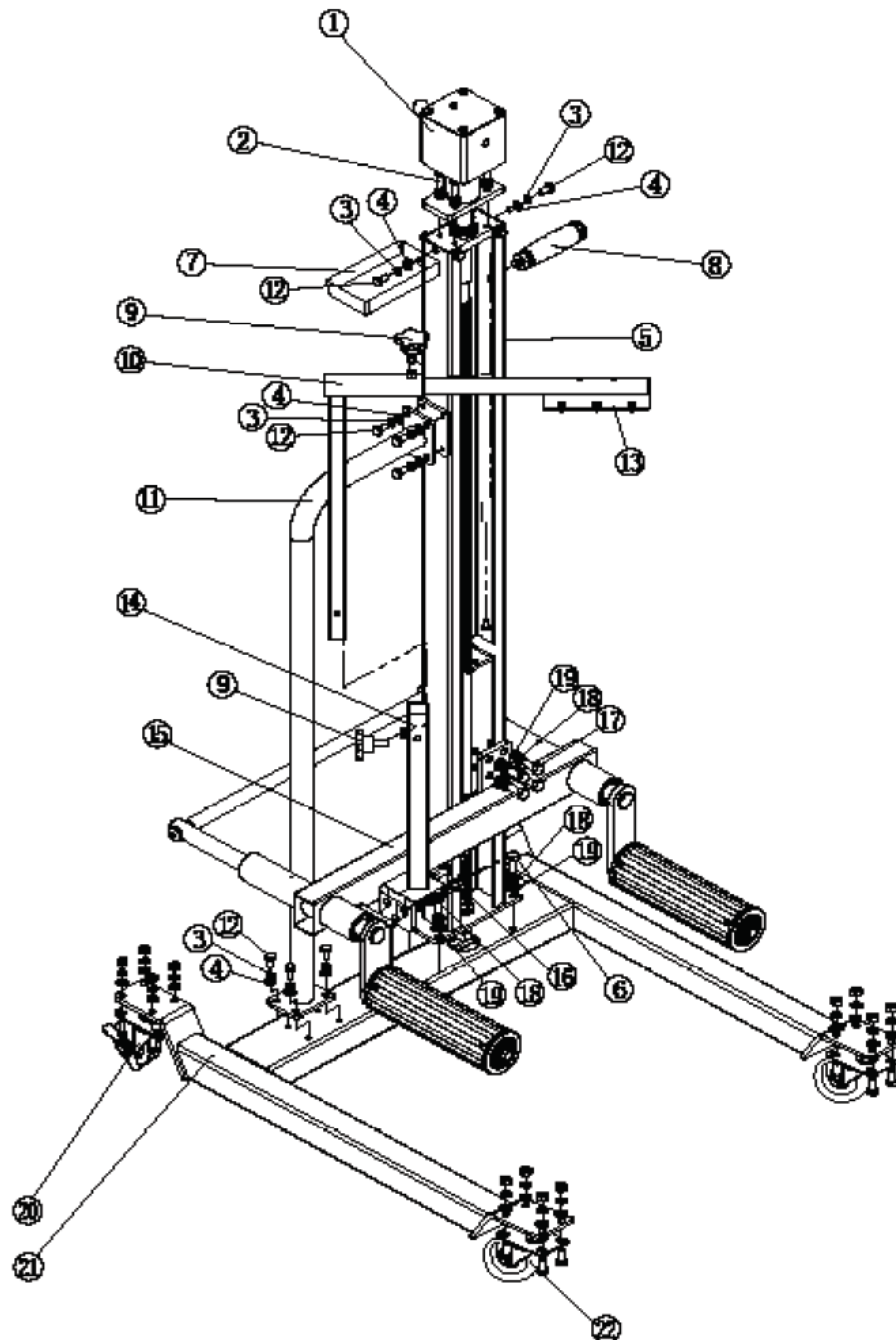



## PRODUCT INFORMATION TOP TIPS

# PRODUCT INFORMATION

## How to extend the life of your Tradequip Wheel & Tyre Lifter

### *10 Top Tips*

### to extend the life of your Tradequip Wheel and Tyre Lifter

- 1** Ensure all assembly bolts and fasteners are positioned correctly and tightened before use.

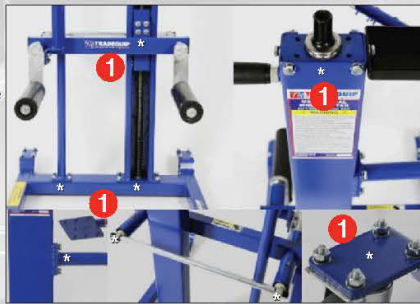

- 2** Regularly lubricate all castors and wheels for ease of movement once loaded.



- 3** Regularly lubricate the lift Screw, Thrust Washer and Roller Shuttle Assembly.

Use a light spray grease and a light grease via the grease nipple for the Extension Slides to ensure smooth operation while raising and lowering the load.



- 4** Regular cleaning recommended.

Regular cleaning of the lift Screw, Thrust Washer and Roller Shuttle Assembly is recommended where used outdoors or in dirty environments. We recommend using an aerosol degreaser liberally sprayed over all components then low pressure rinse avoiding labels and dry then reapply a grease [tip 3].



- 5** Safe operation of your Wheel Tyre Lifter.

To ensure safe operation of your Wheel Tyre Lifter whilst under load, always make sure the roller legs are at 90 degrees to the vehicle wheel and the wheel safety clamp is correctly positioned to allow for smooth operation while raising, lowering, and relocating the wheel.



- 6** Safety Loading.

Tyre width and weight are important factors to consider when using your Tradequip Wheel / Tyre Lifter.

For your safety you should not exceed the 50Kg Load Rating, 300mm Maximum tyre width.

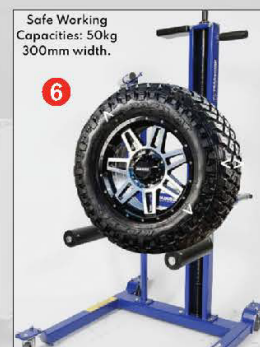

- 7** Raising and Lowering of the Lifter.

Is accomplished by engaging a 1/2" drive tool with the 1/2" drive socket at the top of the main upright. The drive tool can be a 1/2" air impact gun or 1/2" rechargeable impact gun. Operating the drive tool in a clockwise direction will raise the lift rack assembly and operating in reverse will lower the lift rack.



- 8** Hazards and Obstructions.

All wheeled TQB Brands equipment must be used on smooth surface free of cracks, crevices and tripping hazards that can foul the wheels during operation or relocation.

- 9** Correct storage is vital for longevity.

Always store the Wheel/Tyre Lifter in a dry dust free area to minimise corrosion and keep the worm drive and lift rack assembly clean.

- 10** Read the user Manual thoroughly and keep a copy easily accessible or visit our webpage [www.tqbbrands.com.au](http://www.tqbbrands.com.au) for instructional documents & pre-start videos.

**TQ TRADEQUIP**  
the trusted brand in equipment

**TQ PRO**  
Trusted by serious professionals

**BORUM**  
INDUSTRIAL WORKSHOP EQUIPMENT



## WARRANTY

TradeQuip products have been carefully tested and inspected before shipment and are guaranteed to be free from defective materials and workmanship for a period of 12 months from the date of purchase except where tools are hired out when the guarantee period is ninety days from the date of purchase.

Should the machine develop any fault, please return the complete tool to your nearest authorised warranty repair agent or contact TQB Brands Pty Ltd Warranty team – [warranty@tqbbrands.com.au](mailto:warranty@tqbbrands.com.au).

If upon inspection it is found that the fault occurring is due to defective materials or workmanship, repairs will be carried out free of charge. This guarantee does not apply to normal wear and tear, nor does it cover any damage caused by misuse, careless or unsafe handling, alterations, accident, or repairs attempted or made by any personnel other than the authorised TQB Brands Pty Ltd repair agent.

This guarantee applies in lieu of any other guarantee expressed or implied and variations of its terms are not authorised.

Your TQB Brands Pty Ltd guarantee is not effective unless you can produce upon request a dated receipt or invoice to verify your proof of purchase within the 12 month period.

### Consumer Guarantee

Our goods come with a guarantee that cannot be excluded under the Australian Consumer Law. You are entitled to a replacement or refund for a major failure and compensation for any other reasonably foreseeable loss or damage. You are also entitled to have the goods repaired or replaced if the goods fail to be of acceptable quality and the failure does not amount to a major failure.



All images and illustrations shown are for reference purposes only. All information, specifications and illustrations in this manual are based on the latest information available at the time of publication and are subject to change without notice. The information in this manual is periodically revised to ensure the latest information is included. Download the latest version of this manual and other related technical documentation from [www.tqbbrands.com.au](http://www.tqbbrands.com.au)