

Owners Manual

Product Code: 1064T

MADE FOR THE
TRADE

TQ TRADEQUIP
the trusted brand in equipment

HYDRAULIC PRESS



Specifications:

- Safe Working Capacity: 30,000kg
- Working Range: 50-1030mm
- Overall Height: 1950mm
- Overall Width: 720mm
- Overall Depth: 660mm
- Bed Width: 460mm
- Piston Ram Stroke: 170mm

About the Tradequip brand

The 'Tradequip' brand of workshop equipment, is designed for use in a demanding workshop environment by professional users. With proven and trusted "Made for the Trade" reliability, 'Tradequip' branded products offer the very best in performance for an affordable price. All backed by a 1 year trade guarantee across 1,000+ distributors Australia wide.

TQ TRADEQUIP
the trusted brand in equipment

TQPRO
Trusted by service professionals

BORUM
INDUSTRIAL WORKSHOP EQUIPMENT

WARNING

IMPORTANT: READ ALL INSTRUCTIONS BEFORE USE



WARNING

The instructions and warnings contained in this manual should be read and understood before using or operating this equipment. Do not allow anyone to use or operate this equipment until they have read this manual and have developed a thorough understanding of how this equipment works. Failure to observe any of the instructions contained in the manual could result in severe personal injury to the user or bystanders, or cause damage to the equipment and property. Keep this manual in a convenient and safe place for future reference.

Whilst every effort has been made to ensure accuracy of information contained in this manual, the TQB Brands Pty Ltd policy of continuous improvement determines the right to make modifications without prior warning.

CONTENT

WARNING 2

CONTENT 2

STANDARD OPERATING PROCEDURE 3

ASSEMBLY, OPERATION, PREVENTITIVE MAINTENANCE..... 4

PARTS LIST **Error! Bookmark not defined.**

TROUBLE SHOOTING 9

WARRANTY 10

STANDARD OPERATING PROCEDURE

DO NOT use this machine unless you have been trained and assessed to a competent level in its safe use and operation, and have been given permission to use this



Safety glasses must be worn when operating this equipment



Long loose hair must be contained when operating this equipment



Safety footwear must be worn when operating this equipment



Close fitting/protective clothing must be worn when operating this equipment



Rings and jewellery must not be worn when operating this equipment

 **WARNING**

FAILURE TO READ THESE WARNINGS MAY RESULT IN PROPERTY DAMAGE & PERSONAL INJURY

PRE-OPERATIONAL SAFETY CHECKS

- Inspect the Hydraulic Workshop Press before each use. Do not use if bent, broken, cracked, leaking or otherwise damaged. Ensure all bolts and nuts are firmly tightened.
 - Never use a handle longer than supplied for the hydraulic pump
 - Do not exceed the products rated maximum load capacity. Never apply excessive force to a work piece.
 - Always lift the workpiece as close to the ram as possible to minimise ram travel
 - Steel and other materials can shatter, always wear approved impact goggles, heavy duty work gloves and appropriate clothing.
 - If you detect anything that may indicate imminent structural failure, stop using the Hydraulic Workshop Press immediately and inspect thoroughly.
 - Only use this Hydraulic Workshop Press on a surface that is stable, level, dry and non-slippery, and capable of sustaining the load. Keep the surface clean, tidy and free from unrelated materials and ensure that there is adequate lighting.
 - Do not use this Hydraulic Workshop Press to compress springs or any other item that could disengage and cause a potential hazard.
 - Keep hands and feet away from bed area at all times.
 - Always use the press plates as a pair and equality distribute the weight against the pair of press plates.
 - Do not modify any component of this equipment.
 - Only use this device for the purpose for which it has been designed.
 - Always ensure the contact point on the ram is on the centre of the ram head/face. Do not apply force from the ram off-centred
 - Use press pins whenever practical and safe to do so
 - When servicing, use only TradeQuip identical replacement parts. Use of any other parts will void the warranty.
 - Use the right product for the job. There are certain applications for which the Hydraulic Workshop Press was designed. Do not modify the Hydraulic Workshop Press and do not use the Hydraulic Workshop Press for a purpose for which it was not intended.
- **Do not force the product. Products are safer and do a better job when used in the manner for which they are designed. Plan your work, and use the correct product for the job.**
 - **Be aware of dynamic loading. A sudden loading movement may briefly create an excess load causing product failure.**

INTENDED USE

For regular professional straightening, bending & pressing. Removing and installing gears, bearings and bushings.

ASSEMBLY, OPERATION, PREVENTITIVE MAINTENANCE

1. FEATURES

This *TradeQuip "Made for the Trade"* Hydraulic Workshop Press is great for straightening, stamping, bending and pressing any component that is hard to handle. The polished inner cylinder walls extend the life of the hydraulic seals to minimize abrasion and wear, while the cylinder ram and pistons are also polished and chromed, guided by high performance seals, wear rings and dust seals.

It is ideal for a variety of workshop applications and in particular suited to agricultural or industrial use. Jobs such as straightening, bending, folding, punching, removing bolts and bearings etc, are some of the tasks that can be easily accomplished.

2. ASSEMBLY

Unpacking: after removing the packing material, make sure the product is in perfect condition and that there are no visible damaged parts. The packaging materials (Polyethylene bags, polystyrene etc.), must be disposed of in an appropriate refuse collection container. These materials must not be left within the reach of children as they are potential sources of danger.

- Identify and lay out parts. Bolt the cross legs to the bottom of the main frames.
- Bolt the upper crossbeam to the head of the main frames. Note. If your model has a top and bottom plate which attach to either side of the frame head, screw the nuts finger tight only at this stage.
- Insert the press platform support pins through the holes in the main frame. Taking firm hold of the platform, tip it into a diagonal position so that it can be introduced between the mainframe uprights and carefully lower it back to a horizontal position to rest on the support pins.

WARNING! Take care not to allow the press platform to drop onto the pins and ensure your hands and fingers are clear of the press platform when lowering.

3. BEFORE USE

Prior to each use conduct a visual inspection by checking for abnormal conditions, such as cracked and damaged, loose, or missing parts.

Installation

- Securely attach the Hydraulic Workshop Press to a flat, firm, level surface taking into account clearance for working pieces.
- Before operating the press, purge the hydraulic system in order to eliminate any air that may have built up during transit. Open the release valve and pump the handle several times and close the release valve. Should the system malfunction at any time, repeating this process may resolve the problem.

DANGER! Models are purpose designed to withstand greater loads than the hydraulic units can develop. For safety reasons, always ensure the workpiece and press tools are secured on the table and will not flex or suddenly "give way" causing danger to operator or the component. Also ensure you have read and understood safety instructions.

4. OPERATION

- **Do not force the product. Products are safer and do a better job when used in the manner for which they are designed. Plan your work, and use the correct product for the job.**
- **Be aware of dynamic loading. A sudden loading movement may briefly create an excess load causing product failure.**
 - Check that the hydraulic unit is fully closed ready for operating.
 - Position the working table at highest operating height possible for the job at hand by inserting the support pins into the appropriate holes in the main frame.
 - Position the arbor plate or press tools to be used onto the work table and align beneath the ram. Place workpiece onto the work table or arbors and align beneath the ram as required. Note: Care must be taken to ensure an arbor does not fall from the press work table. If necessary hold the configuration in position with clamps. Always use the press plates as a pair and always ensure working piece is evenly spread across the plates
 - Operate the pump slowly until the ram is close to or just touching the workpiece. Before applying real pressure to the workpiece recheck the alignment with the ram and ensure that the workpiece and press tools are supported in such a way that they cannot flex to breaking point. DO NOT exceed the stroke indicated and do not apply off centre loads.

- When work is complete release the pressure back to fully closed position using the release valve and the piston/ram head will retract automatically.

Note: Always keep the piston fully retracted after use to avoid corrosion

5. STORAGE

This Hydraulic Workshop Press should always be stored in a dry location with the ram and piston fully retracted on a level surface.

6. MAINTENANCE

- Check all fittings are tight before each use.
- Lubricate all moving parts at regular intervals.
- Always keep the press clean, dry, and protected from harsh conditions.
- Should you need to replace the oil ensure the piston is fully retracted. An excess of oil will render the press inoperative.
- Use only good quality hydraulic jack oil. DO NOT use brake fluid. Contact your local dealer for details.
- Purge the system to remove any air.

7. SERVICE & REPAIR

Any Hydraulic Workshop Press found damaged in any way, or found to be worn or operates abnormally should be removed from service until repaired by an authorised service agent. Owners and / or operators should be aware that repair of this product may require specialised equipment and knowledge. Only authorised parts, labels and decals shall be used on this equipment. Annual inspection of the Hydraulic Workshop Press is recommended and can be made by an authorised repair facility to ensure that your equipment is in optimum condition and that the equipment has the correct decals and safety labels specified by the manufacturer.

PARTS LIST – 1064T

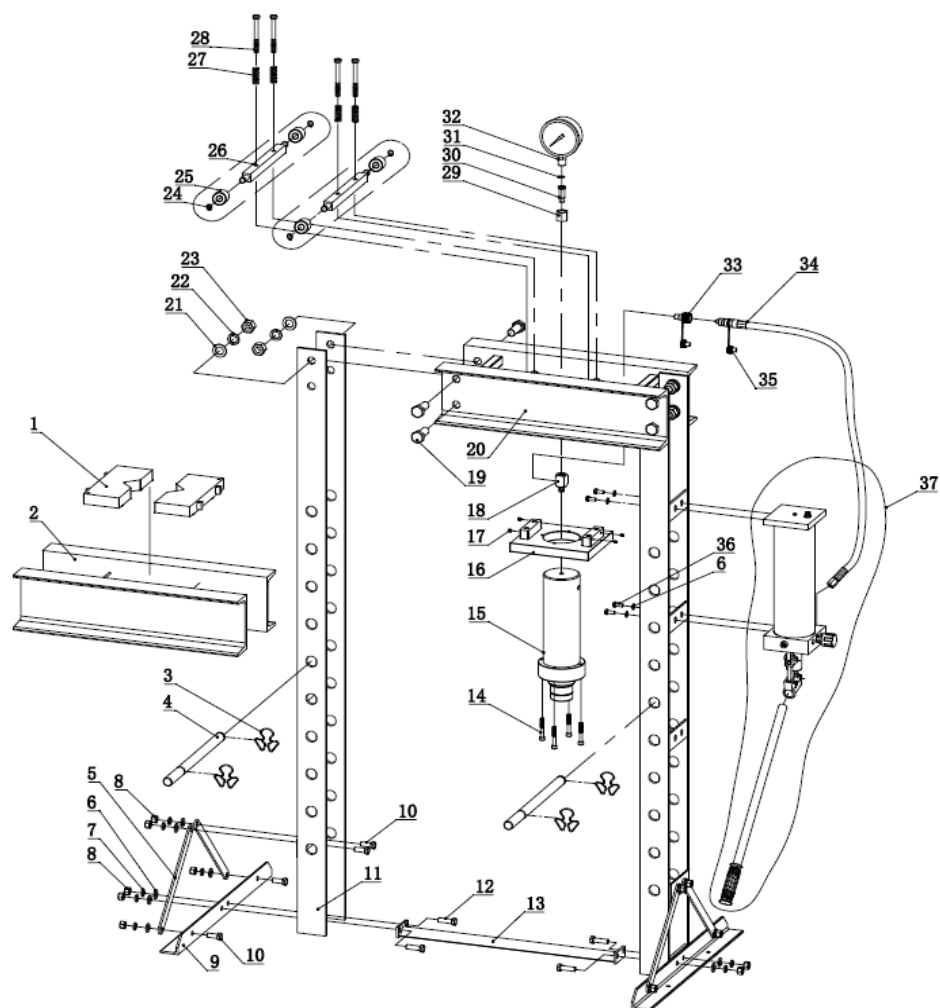

Part #	Description	Qty	Part #	Description	Qty
1	Steel Block	2	20	Upper Beam	1
2	Bed Frame	1	21	Washer	8
3	Circlip	4	22	Lock Washer	8
4	Pin	2	23	Nut	8
5	Support	4	24	Retainer Ring	4
6	Washer	16	25	Roller	4
7	Lock Washer	12	26	Location Beam	2
8	Nut	12	27	Spring	4
9	Leg	2	28	Bolt	4
10	Bolt	8	29	Nut	1
11	Upright	2	30	Connector	1
12	Bolt	4	31	Nylon Washer	1
13	Lower Beam	1	32	Pressure Gauge	1
14	Screw	4	33	Connector	1
15	Ram Ass'Y	1	34	Oil Hose	1
16	Ram Plate	1	35	Dust Cap	1
17	Screw	4	36	Bolt	4
18	Connector	1	37	Pump Ass'Y	1
19	Bolt	8			

PARTS LIST – 1064T

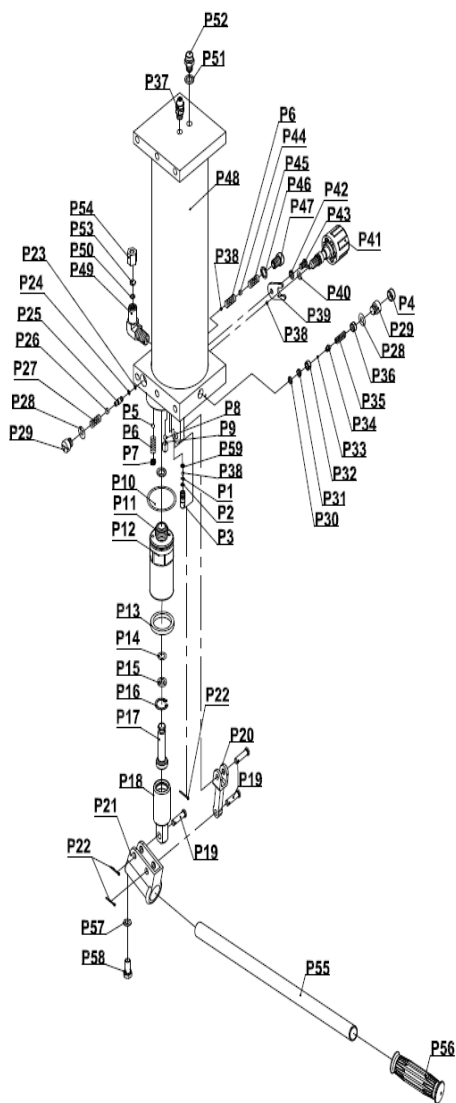

Part #	Description	Qty	Part #	Description	Qty
1	O-Ring	1	31	Seal Ring	1
2	Washer	1	32	Screw	1
3	Valve Seat	1	33	Valve Ball	1
4	Red Cap	1	34	Steel Ball Seat	1
5	Steel Ball	1	35	Spring	1
6	Spring	2	36	Screw	1
7	Screw	1	37	Connector	1
8	Steel Ball	1	38	Stell Ball	3
9	Square Steel Tube	1	39	Limited Ring	1
10	Copper Washer	1	40	O-Ring	1
11	O-Ring	1	41	Release Valve	1
12	Piston Seat	1	42	Lock Washer	1
13	U-Ring	1	43	Screw	1
14	O-Ring	1	44	Steel Ball	1
15	Nylon Retainer Ring	1	45	Spring	1
16	Retainer Ring	1	46	Copper Washer	1
17	Small Piston	1	47	Screw	1
18	Big Piston	1	48	Pump Base	1
19	Pin	3	49	Connector	1
20	Link Rod	1	50	O-Ring	1
21	Handle Socket	1	51	Nylon Washer	1
22	Cotter Pin	3	52	Air Venting Screw	1
23	O-Ring	1	53	Nylon Washer	1
24	Nylon Washer	1	54	Nut	1
25	Control Valve Rod	1	55	Handle Tube	1
26	Steel Ball	1	56	Handle Cover	1
27	Spring	1	57	Washer	1
28	O-Ring	2	58	Bolt	1
29	Screw	2	59	Washer	1
30	Copper Washer	1			

PARTS LIST – 1064T

Part #	Description	Qty
R1	Pin	1
R2	Screw	1
R3	Ra,	1
R4	Spring Ass'Y	1
R5	Nut	1
R6	Screw	1
R7	U-Ring	1
R8	Washer	1
R9	Piston Head	1
R10	O-Ring	1
R11	Washer	1
R12	Piston Rod	1
R13	Screw	1
R14	Copper Washer	1
R15	Screw	1
R16	Lower Round Nut	1
R17	Saddle	1
R18	Nylon Block	1
R19	Screw	1

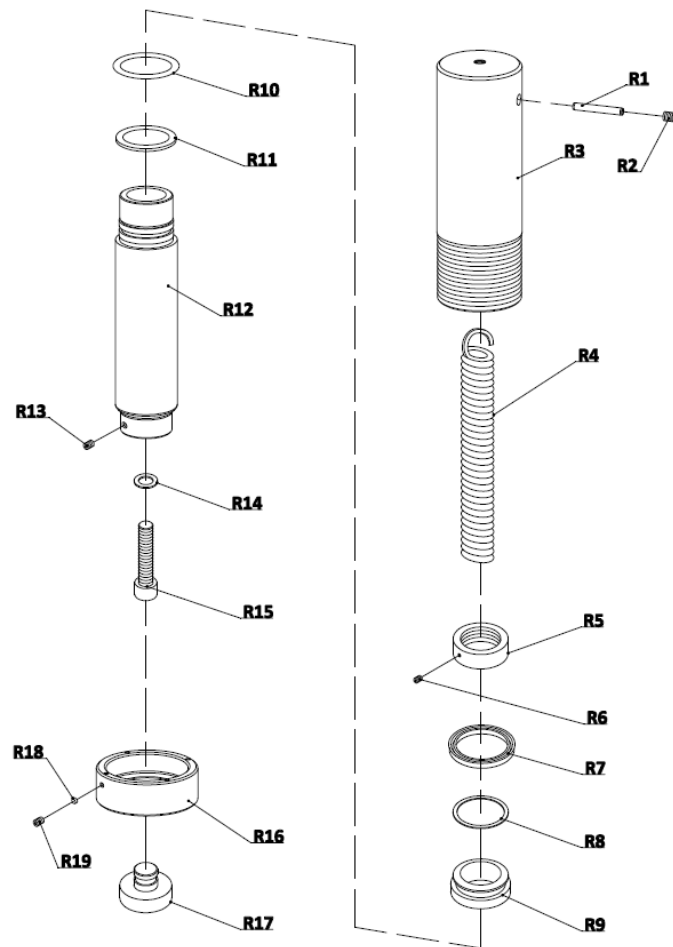

TROUBLE SHOOTING

PROBLEM	SYMPTOM	CAUSE	CONCLUSION	SOLUTION
Ram will not Build Pressure	<p>Pump has resistance but no ram force</p> <p>Pump has no resistance, ram will not apply force</p> <p>Pump has no resistance, ram will not apply force</p> <p>Pump has no resistance, ram will not apply force</p>	<p>Release valve not tightly closed</p> <p>Air in Hydraulic system</p> <p>Overload actuated</p> <p>Force required exceeds Ram Capacity, Overload actuated</p>	<p>Bypass through release valve</p> <p>Air cavitation in pump and or lift ram</p> <p>Relief valve needs reset</p> <p>Higher capacity pressing tool required Relief valve needs reset</p>	<p>Ensure Release tightly closed</p> <p>Bleed system</p> <p>Contact Qualified Technician for repairs</p> <p>Select Higher Capacity Press Contact Qualified Technician for repairs</p>
Ram will not hold load	<p>Load cannot be sustained, lift ram retracts under load</p> <p>Load cannot be sustained, ram retracts under load</p> <p>Load cannot be sustained; ram retracts under load Pump handle rises</p>	<p>Release valve not tightly closed</p> <p>Damaged Main Seal</p> <p>Main check valve obstructed</p>	<p>Bypass through release valve</p> <p>Replace main ram seals</p> <p>Replace Main check valve ball and reseal valve seat</p>	<p>Contact Qualified Technician for repairs</p> <p>Contact Qualified Technician for repairs</p> <p>Contact Qualified Technician for repairs</p>
Ram will not retract after unloading	<p>Ram rises after retracting</p> <p>Release valve pin siezed</p>	<p>Reservoir overfilled</p> <p>Linkages binding</p>	<p>Pump failure due to cavitation caused by excess reservoir level</p> <p>Dry release valve pin</p>	<p>Bleed system</p> <p>Lubricate release valve 32gr Hydraulic oil</p>
Poor force performance	<p>Pump has no resistance, ram will not extend to full stroke</p> <p>Pump has no resistance; ram will not extend to full stroke</p>	<p>Fluid level low</p> <p>Air trapped in system</p>	<p>Drain fluid to correct level</p> <p>Ram extended for extended period causing air ingress to hydraulic system</p>	<p>Fill fluid to correct level then bleed system</p> <p>With ram fully retracted, remove oil filler plug to let pressurised air escape reinstall oil filler plug, Bleed system</p>
Press jack Will not extend to full extension	Ram has limited stroke, pump loses resistance	Fluid level low	Lift ram raised for extended period causing air ingress to hydraulic system	Fill fluid to correct level then bleed system

WARRANTY

TradeQuip products have been carefully tested and inspected before shipment and are guaranteed to be free from defective materials and workmanship for a period of 12 months from the date of purchase except where tools are hired out when the guarantee period is ninety days from the date of purchase.

Should this piece of equipment develop any fault, please return the complete tool to your nearest authorised warranty repair agent or contact TQB Brands Pty Ltd Warranty team – warranty@tqbbrands.com.au.

If upon inspection it is found that the fault occurring is due to defective materials or workmanship, repairs will be carried out free of charge. This guarantee does not apply to normal wear and tear, nor does it cover any damage caused by misuse, careless or unsafe handling, alterations, accident, or repairs attempted or made by any personnel other than the authorised TQB Brands Pty Ltd repair agent.

This guarantee applies in lieu of any other guarantee expressed or implied and variations of its terms are not authorised.

Your TQB Brands Pty Ltd guarantee is not effective unless you can produce upon request a dated receipt or invoice to verify your proof of purchase within the 12 month period.

Consumer Guarantee

Our goods come with a guarantee that cannot be excluded under the Australian Consumer Law. You are entitled to a replacement or refund for a major failure and compensation for any other reasonably foreseeable loss or damage. You are also entitled to have the goods repaired or replaced if the goods fail to be of acceptable quality and the failure does not amount to a major failure.



All images and illustrations shown are for reference purposes only. All information, specifications and illustrations in this manual are based on the latest information available at the time of publication and are subject to change without notice. The information in this manual is periodically revised to ensure the latest information is included. Download the latest version of this manual and other related technical documentation from www.tqbbrands.com.au.