

Owners Manual

Product Code: 1198T

**MADE FOR THE
TRADE**

TQ TRADEQUIP
the trusted brand in equipment

**UNDERHOIST
AUXILIARY STAND**



Specifications

- Safe Working Capacity: 680kg
- Minimum Height: 1370mm
- Maximum Height: 2045mm
- Base Diameter: 300mm
- Carton: 1390 x 370 x 90mm
- Weight: 16.5kg

About the TradeQuip brand

The 'TradeQuip' brand of workshop equipment, is designed for use in a demanding workshop environment by professional users. With proven and trusted "Made for the Trade" reliability, 'TradeQuip' branded products offer the very best in performance for an affordable price. All backed by a 1 year trade guarantee across 1,000+ distributors Australia wide.

TQ TRADEQUIP
the trusted brand in equipment

TQPRO
Trusted by serious professionals

BORUM
INDUSTRIAL WORKSHOP EQUIPMENT

WARNING INFORMATION**IMPORTANT: READ ALL INSTRUCTIONS BEFORE USE** **WARNING**

The instructions and warnings contained in this manual should be read and understood before using or operating this equipment. Do not allow anyone to use or operate this equipment until they have read this manual and have developed a thorough understanding of how this equipment works. Failure to observe any of the instructions contained in the manual could result in severe personal injury to the user or bystanders, or cause damage to the equipment and property. Keep this manual in a convenient and safe place for future reference.

Whilst every effort has been made to ensure accuracy of information contained in this manual, the TradeQuip policy of continuous improvement determines the right to make modifications without prior warning.

CONTENT

WARNING INFORMATION	2
CONTENT	2
STANDARD OPERATING PROCEDURE	3
SAFETY CHECKS.....	3
ASSEMBLY, OPERATION & PREVENTATIVE MAINTENANCE	4
PARTS DIAGRAM & LIST.....	5
WARRANTY	6

STANDARD OPERATING PROCEDURE

DO NOT use this machine unless you have been trained and assessed to a competent level in its safe use and operation, and have been given permission to use this



Safety glasses must be worn when operating this equipment



Long loose hair must be contained when operating this equipment



Safety footwear must be worn when operating this equipment



Close fitting/protective clothing must be worn when operating this equipment



Rings and jewellery must not be worn when operating this equipment

SAFETY CHECKS**PRE-OPERATIONAL SAFETY CHECKS**

- Check vehicle owner's manual for correct component weight - DO NOT exceed parts stands' safe working capacity.
- Use only for partial support of vehicle components during removal and installation
- Use only as specified by the manufacturer.
- Do not use this stand to support or stabilise a vehicle.
- Use only on a hard, level surface.
- Securely support the vehicle before placing parts stands in place.
- Place component in centre of saddle.
- For your safety, do not modify or alter these auxiliary parts stands.
- Use the right product for the job. There are certain applications for which the stand was designed. Do not modify the Stand and do not use the stand for a purpose for which it was not intended.

INTENDED USE

For or partial support of vehicle components during removal and installation of components

ASSEMBLY, OPERATION & PREVENTATIVE MAINTENANCE

1. FEATURES

TradeQuip Auxiliary Parts Stands are intended to be used as a means of partial support and the positioning of vehicle components during their installation/removal. The Auxiliary Parts Stand is **not** for use in stabilising or supporting vehicles. These are for use under a 2 or 4 post overhead vehicle lift or in a garage pit. Heavy gauge steel construction to ensure safety, strength and stability.

2. ASSEMBLY

1. Insert smaller end of threaded column through the bottom of upright, allowing small end of threaded column to project out of the top of upright.
2. Place bearing over threaded portion with upright/threaded column assembly in the horizontal position.
3. Spin adjusting handle clockwise onto threaded portion.
4. Insert the roll pin through saddle & threaded column to fasten saddle.
5. Insert upright assembly onto base with slot in upright facing foot pedal mount.
6. Secure upright using the larger pin, washer and r-clip.
7. Insert pedal into slot and secure with remaining pin, washer, and r-clip.

3. BEFORE USE

Conduct a thorough visual inspection checking for any abnormal conditions, such as cracked welds, and damaged, loose, or missing parts.

4. OPERATION

Prior to each use always conduct a visual inspection checking for any abnormal conditions, such as cracked welds, and damaged, loose, or missing parts.

To Raise:

- Turn adjusting handle clockwise until saddle contacts load. Be sure to centre load on saddle.
- Slight upward adjustments can be made to the saddle height by pressing downward on the foot pedal.
- This may or may not be necessary depending on the application. It is provided as a means of making temporary adjustments on load height without using your hands. This leaves your hands free to engage, handle and control the workpiece.



WARNING

- The stands must be positioned on a hard level (concrete) surface.
- The safe working load must not be exceeded under any circumstances.
- DO NOT lower overhead lift in order to accommodate load on stand.
- Contact with the desired vehicle component shall only be done by means of the vertical adjustments provided on the stand.
- Always centre the component load on the saddle.

To Lower Vehicle:

- Turn adjusting handle counter clockwise
- Carefully remove stand from underneath vehicle.
- Slowly lower vehicle to the ground with overhead lift hoist control.

5. STORAGE

These Jack Stands should always be stored in a dry indoor location in the upright position.

6. MAINTENANCE

Periodically inspect each stand. Ensure all parts move freely. Do not apply oil or grease to any part of this product. If rust appears, sand the affected area and cover with suitable paint. This product has no replacement parts.

7. SERVICE & REPAIR

Any Auxiliary Parts Stands found damaged in any way, or found to be worn or operates abnormally should be removed from service until repaired by an authorised service agent. Owners and / or operators should be aware that repair of this product may require specialised equipment and knowledge. Only authorised parts, labels, decals shall be used on this equipment. Annual inspection of the Jack Stands is recommended and can be made by an authorised repair facility to ensure that your equipment is in optimum condition and that the equipment has the correct decals and safety labels specified by the manufacturer.

PARTS DIAGRAM & LIST

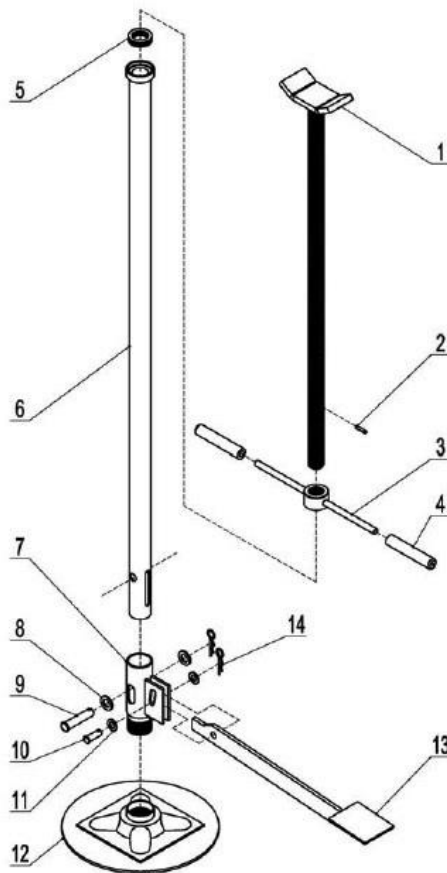

Part #	Description	QTY	Part #	Description	QTY
1	Lifting Screw	1	8	Flat Washer 16	2
2	Spring 6x26	1	9	Clevis Pin with Head 16x70	1
3	Handle	1	10	Clevis Pin with Head 12x35	1
4	Handle Sleeve	2	11	Flat Washer 12	2
5	Bearing	1	12	Base	1
6	Upright Column	1	13	Foot Bar	1
7	Pedal Lever	1	14	"R" Clip	2

WARRANTY

TradeQuip products have been carefully tested and inspected before shipment and are guaranteed to be free from defective materials and workmanship for a period of 12 months from the date of purchase except where tools are hired out when the guarantee period is ninety days from the date of purchase.

Should the machine develop any fault, please return the complete tool to your nearest authorised warranty repair agent or contact TQB Brands Pty Ltd Warranty team – warranty@tqbbrands.com.au.

If upon inspection it is found that the fault occurring is due to defective materials or workmanship, repairs will be carried out free of charge. This guarantee does not apply to normal wear and tear, nor does it cover any damage caused by misuse, careless or unsafe handling, alterations, accident, or repairs attempted or made by any personnel other than the authorised TQB Brands Pty Ltd repair agent.

This guarantee applies in lieu of any other guarantee expressed or implied and variations of its terms are not authorised.

Your TQB Brands Pty Ltd guarantee is not effective unless you can produce upon request a dated receipt or invoice to verify your proof of purchase within the 12 month period.

Consumer Guarantee

Our goods come with a guarantee that cannot be excluded under the Australian Consumer Law. You are entitled to a replacement or refund for a major failure and compensation for any other reasonably foreseeable loss or damage. You are also entitled to have the goods repaired or replaced if the goods fail to be of acceptable quality and the failure does not amount to a major failure.



All images and illustrations shown are for reference purposes only. All information, specifications and illustrations in this manual are based on the latest information available at the time of publication and are subject to change without notice. The information in this manual is periodically revised to ensure the latest information is included. Download the latest version of this manual and other related technical documentation from www.tqbbrands.com.au.