

Owners Manual

Product Code: 1891T

**MADE FOR THE
TRADE**

TQ TRADEQUIP
the trusted brand in equipment

ENGINE



Specifications:

- Safe Working Capacity: 680kg
- Operating Height: 895mm
- Width: 800mm
- Length: 870mm
- Distance between legs: 670mm
- Lower steel tubing: 70x70mm
- Column tubing: 60x60mm
- Column base tubing: 70x76mm
- Leg tubing: 60x60mm
- Mounting head plate: 248x149mm
- Mounting head plate (with fingers): 360x245mm
- Nett Weight: 39kg
- Carton: 870 x 240 x 210mm
- Gross Weight: 41kg

About the TradeEquip brand

The 'TradeEquip' brand of workshop equipment, is designed for use in a demanding workshop environment by professional users. With proven and trusted "Made for the Trade" reliability, 'TradeEquip' branded products offer the very best in performance for an affordable price. All backed by a 1year trade guarantee across 1,000+ distributors Australia wide.

TQ TRADEQUIP
the trusted brand in equipment

TQpro
Trusted by serious professionals

BORUM
INDUSTRIAL WORKSHOP EQUIPMENT

WARNING

IMPORTANT: READ ALL INSTRUCTIONS BEFORE USE



WARNING

The instructions and warnings contained in this manual should be read and understood before using or operating this equipment. Do not allow anyone to use or operate this equipment until they have read this manual and have developed a thorough understanding of how this equipment works. Failure to observe any of the instructions contained in the manual could result in severe personal injury to the user or bystanders, or cause damage to the equipment and property. Keep this manual in a convenient and safe place for future reference.

Whilst every effort has been made to ensure accuracy of information contained in this manual, the TQB Brands Pty Ltd policy of continuous improvement determines the right to make modifications without prior warning.

CONTENT

WARNING 3

CONTENT 3

STANDARD OPERATING PROCEDURE 4

ASSEMBLY, OPERATION, PREVENTITIVE MAINTENANCE 5

PARTS DIAGRAM 6

PARTS LIST 6

PRODUCT INFORMATION TOP TIPS 7

WARRANTY 8

STANDARD OPERATING PROCEDURE

DO NOT use this machine unless you have been trained and assessed to a competent level in its safe use and operation, and have been given permission to use this



Safety glasses must be worn when operating this equipment



Long loose hair must be contained when operating this equipment



Safety footwear must be worn when operating this equipment



Close fitting/protective clothing must be worn when operating this equipment



Rings and jewellery must not be worn when operating this equipment

WARNING

ENGINE DIMENSIONS MUST BE WITHIN LEGS OF ENGINE STAND

PRE-OPERATIONAL SAFETY CHECKS

Before using the stand ensure it is in sound condition, and good working order.

- Replace or repair damaged parts. Use recommended parts only. Non-authorized parts may be dangerous and will invalidate the warranty.
- Keep the stand clean for best and safest performance.
- Locate the stand in an adequate working area for its function, keep area clean and tidy and free from unrelated materials, and ensure there is adequate lighting.
- Use on a firm, level surface capable of sustaining the stand and the load.
- Maintain correct balance and footing. Ensure the floor is not slippery and wear non-slip shoes.
- Ensure all non-essential persons keep a safe distance whilst the stand is in use.
- Lock mounting plate in position before fixing a load, and ensure the load is centred and securely mounted on the locking plate.
- Ensure the Stand and the load is stable.
- Ensure the engine dimensions are within the engine stand dimensions
- To move a loaded stand, push it from the load side, above the two fixed wheels. DO NOT move the stand from the castor end and never pull the stand towards yourself. Also ensure surface over which the stand is to travel is strong enough to take the stand load and that it is not cracked, uneven or obstructed.
- DO NOT operate unit if damaged.
- DO NOT allow untrained persons to operate the stand.
- DO NOT exceed the rated capacity of 680kg.
- **DANGER: DO NOT work under an engine mounted on the stand.**

INTENDED USE

Safely supports an engine in place during repairs after being removed from vehicle by and engine crane

ASSEMBLY, OPERATION, PREVENTITIVE MAINTENANCE

1. FEATURES

The 1891T Tradequip Engine Stand accepts a wide variety of engines and transmissions. The head swivels 360° for accessibility to all parts of the engine. It has fully adjustable mounting arms. Ball bearing swivel castors provide excellent maneuverability.

2. ASSEMBLY

 **WARNING:** During the assembly procedure, nuts and bolts should be hand tightened only. Once assembly is complete, nuts and bolts must be fully tightened.

1. Attach the two front 3.5" wheels (#15) to legs (#14) using bolts (#18), nuts (#17) and lock washers (#16)
2. Attach the two rear 3" wheels (#13) to rear beam (#9) using nuts (#12) and lock washers (#11)
3. Attach the two legs (#14) to rear beam and secure it with bolts (#10).
4. Insert main post (#8) into the tube of rear beam assembly (#9) and secure it with bolt (#10).
5. Insert rotating plate (#6) through the tube at the top of the main post. Rotate the plate until one of the holes in the inner tube is aligned with a hole in the outer tube and insert the ringed pin (#7).
6. Insert the handle (#1) through the hole in the rotating plate tube which protrudes from the top off the main post.
7. Attach four fingers (#2) to the rotating head (#6) using bolts (#5), flat washers (#3) and nuts (#4).
8. Check all bolts for tightness before operating.

3. BEFORE USE

Prior to each use conduct a visual inspection by checking for abnormal conditions, such as cracked joints and damaged, loose, or missing parts. Ensure the engine dimensions are within the dimensions of the engine stand.

4. STORAGE

This Engine Stand should always be stored in a dry location on a level surface.

5. MAINTENANCE

Replace or repair damaged parts. Use recommended parts only. Non-authorized parts may be dangerous and will invalidate the warranty.

Keep the stand clean for best and safest performance.

6. SERVICE & REPAIR

Any Engine Stand found damaged in any way, or found to be worn or operates abnormally should be removed from service until repaired by an authorised service agent. Owners and / or operators should be aware that repair of this product may require specialised equipment and knowledge. Only authorised parts, labels and decals shall be used on this equipment. Annual inspection of the engine stand is recommended and can be made by an authorised repair facility to ensure that your equipment is in optimum condition and that the equipment has the correct decals and safety labels specified by the manufacturer.

PARTS DIAGRAM

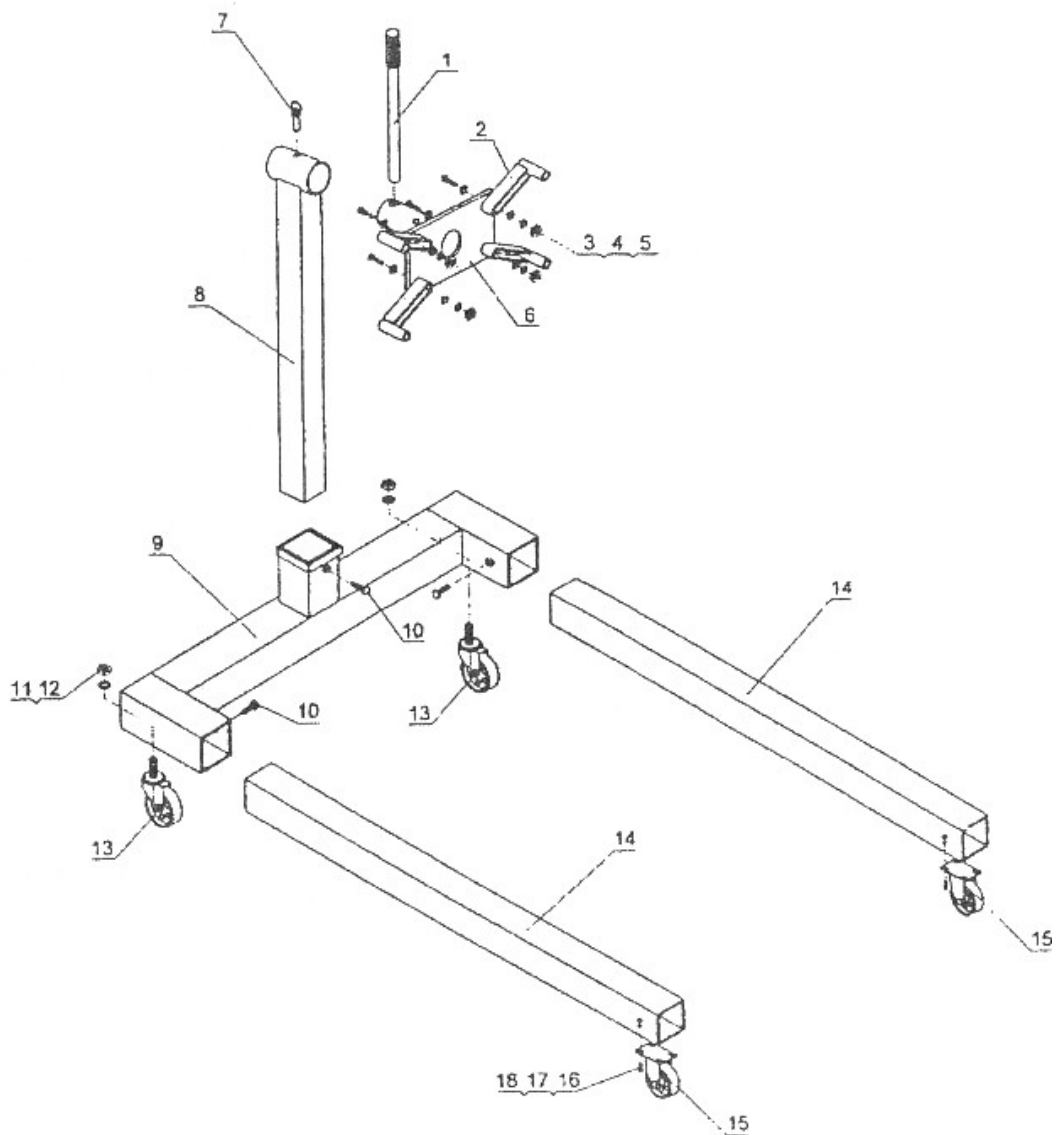

PARTS LIST

Part	Description	Qty	Part	Description	Qty
1	Handle	1	10	Bolt M12x25	3
2	Finger	4	11	Lock Washer °12	2
3	Flat Washer °14	8	12	Nut M12	2
4	Nut M14	4	13	3" Swivel Wheel	2
5	Bolt M14x65	4	14	Leg	2
6	Rotating Plate	1	15	3.5" Wheel	2
7	Pin	1	16	Lock Washer °8	8
8	Main Post	1	17	Nut M8	8
9	Rear Beam	1	18	Bolt M8x20	8

PRODUCT INFORMATION TOP TIPS

PRODUCT INFORMATION

How to extend the life of your Engine Stand

9 Top Tips

to extend the life of your TQB BRANDS Engine Stand

1 Ensure all assembly bolts and fasteners are positioned correctly and tightened before use.



2 Regularly lubricate all castors and wheels for ease of movement once loaded.



3 Always consult the vehicle manufacturer for correct mounting points prior to attaching an engine to your TQB Brands engine stand.



4 Off centre loading or unbalanced loads can affect the smooth rotating operation of engine stand.

Always mount the engine with the crank shaft below the axis of the rotating head plate to provide the safest balance point and to decrease tip over risk while rotating the engine.



5 Where possible minimise the extended length of the upper two attachment adaptors to reduce possible flexing of the headstock plate.



6 Lock mounting plate in position before attaching the engine, and ensure the load is centred and securely mounted on the locking plate prior to releasing from the engine lift.

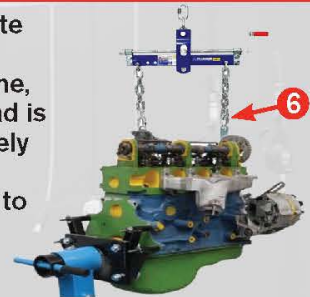

7 Hazards and Obstructions.

All wheeled TQB Brands equipment must be used on smooth surface free of cracks, crevices and tripping hazards that can foul the wheels during operation or relocation.

8 Use correct model for intended applications.

An engines length, width and weight should never exceed the engine stands foot print dimensions or weight specifications.

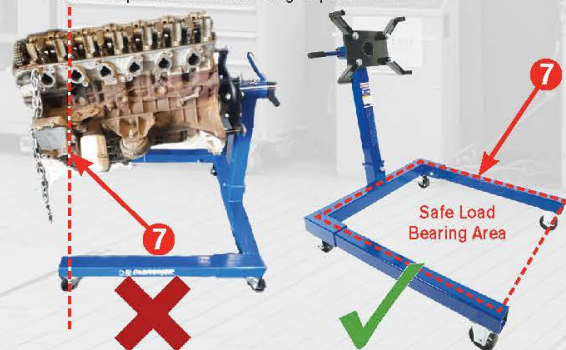

Engine Stand Model	Load Rating	Engine Type/Size/Configuration <small>Example: 10 to 20 (2lt+) Above: 2lt (2lt+)</small>									
		Inline 4Cyl 2lt<	Inline 4Cyl 2lt>	Boxer 4Cyl 2lt<	Boxer 4Cyl 2lt>	Inline 5/6Cyl 4lt<	Inline 5/6Cyl 4lt>	V6 6 Cyl 4lt<	V6 6 Cyl 4lt>	V8 8Cyl 5lt<	V8 8Cyl 5lt>
TQES450	450KG	Y	Y	Y	Y	N	N	N	N	N	N
1894T	500KG	Y	Y	Y	Y	Y	Y	Y	N	N	N
1891T	680KG	Y	Y	Y	Y	N	N	Y	Y	Y	N
1192T	900KG	Y	Y	Y	Y	Y	Y	Y	Y	Y	Y

9 Read the user Manual thoroughly and keep a copy easily accessible or visit our webpage www.tqbbrands.com.au for instructional documents & pre-start videos.



WARRANTY

Tradequip products have been carefully tested and inspected before shipment and are guaranteed to be free from defective materials and workmanship for a period of 12 months from the date of purchase except where tools are hired out when the guarantee period is ninety days from the date of purchase.

Should the machine develop any fault, please return the complete tool to your nearest authorised warranty repair agent or contact TQB Brands Pty Ltd Warranty team – warranty@tqbbrands.com.au.

If upon inspection it is found that the fault occurring is due to defective materials or workmanship, repairs will be carried out free of charge. This guarantee does not apply to normal wear and tear, nor does it cover any damage caused by misuse, careless or unsafe handling, alterations, accident, or repairs attempted or made by any personnel other than the authorised TQB Brands Pty Ltd repair agent.

This guarantee applies in lieu of any other guarantee expressed or implied and variations of its terms are not authorised.

Your TQB Brands Pty Ltd guarantee is not effective unless you can produce upon request a dated receipt or invoice to verify your proof of purchase within the 12 month period.

Consumer Guarantee

Our goods come with a guarantee that cannot be excluded under the Australian Consumer Law. You are entitled to a replacement or refund for a major failure and compensation for any other reasonably foreseeable loss or damage. You are also entitled to have the goods repaired or replaced if the goods fail to be of acceptable quality and the failure does not amount to a major failure.



All images and illustrations shown are for reference purposes only. All information, specifications and illustrations in this manual are based on the latest information available at the time of publication and are subject to change without notice. The information in this manual is periodically revised to ensure the latest information is included. Download the latest version of this manual and other related technical documentation from www.tqbbrands.com.au