

# Owners Manual

Product Code: 2012

**MADE FOR THE  
TRADE**

**TQ TRADEQUIP**  
the trusted brand in equipment

**HYDRAULIC  
BOTTLE JACK**



#### Specifications

- Safe Working Capacity: 10,000kg
- Hydraulic Lift: 130mm
- Adjustable Screw Height: 65mm
- Minimum Height: 200mm
- Maximum Height: 395mm
- Base Area: 124 x 124mm
- Handle: 500 x 20mm
- Carton: 140 x 135 x 215mm (plus handle)
- Gross Weight: 6kg

#### About the Tradequip brand

The 'Tradequip' brand of workshop equipment, is designed for use in a demanding workshop environment by professional users. With proven and trusted "Made for the Trade" reliability, 'Tradequip' branded products offer the very best in performance for an affordable price. All backed by a 1year trade guarantee across 1,000+ distributors Australia wide.

**TQ TRADEQUIP**  
the trusted brand in equipment

**TQPRO**  
Trusted by serious professionals

**BORUM**  
INDUSTRIAL WORKSHOP EQUIPMENT

**WARNING INFORMATION**

**IMPORTANT: READ ALL INSTRUCTIONS BEFORE USE**



The instructions and warnings contained in this manual should be read and understood before using or operating this equipment. Do not allow anyone to use or operate this equipment until they have read this manual and have developed a thorough understanding of how this equipment works. Failure to observe any of the instructions contained in the manual could result in severe personal injury to the user or bystanders, or cause damage to the equipment and property. Keep this manual in a convenient and safe place for future reference.

Whilst every effort has been made to ensure accuracy of information contained in this manual, the TradeQuip policy of continuous improvement determines the right to make modifications without prior warning.

**CONTENT**

WARNING INFORMATION ..... 2

CONTENT ..... 2

ASSEMBLY, OPERATION & PREVENTATIVE MAINTENANCE..... 4

PARTS LIST ..... 6

TROUBLESHOOTING ..... 7

WARRANTY ..... 8

**STANDARD OPERATING PROCEDURE**

**DO NOT** use this machine unless you have been trained and assessed to a competent level in its safe use and operation, and have been given permission to use this



Safety glasses must be worn when operating this equipment



Long loose hair must be contained when operating this equipment



Safety footwear must be worn when operating this equipment



Close fitting/protective clothing must be worn when operating this equipment

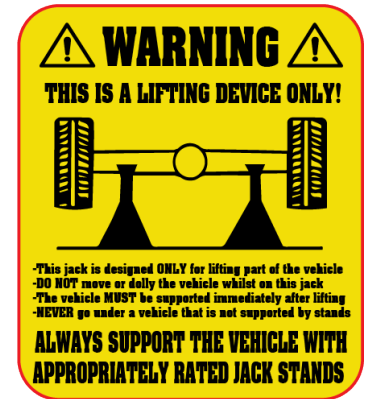

Rings and jewellery must not be worn when operating this equipment

**PRE-OPERATIONAL SAFETY CHECKS**

- Check vehicle owner's manual for correct vehicle weight and jacking points.
- Do not exceed the safe working load limit listed on the jack.
- Use only on a hard, flat, level surface that will sustain the vehicle weight.
- Apply the vehicle parking brake and securely chock wheels remaining on the ground.
- Inspect the jack prior to every use and do not use if parts are worn or jack is damaged.
- Lift only under an appropriate strong position on the vehicle, as specified in the vehicle owner's manual.
- Centre the load prior to lifting and do not move or dolly the vehicle whilst on this jack.
- The jack is a lifting device only. Immediately after lifting, support the vehicle with AS Approved jack stands.
- Do not use this jack for any purpose other than specified by this owner's manual.
- Do not modify this jack and do not use this jack for a purpose for which it was not intended.

**POTENTIAL HAZARDS**

- User does not read, understand and follow the instructions and warnings in this manual prior to operating the jack.
- Work area is not well lit or kept clean and tidy.
- Vehicle load is not immediately supported on AS Approved jack stands prior to commencing work on or under vehicle.
- Not maintaining or servicing this jack to the manufacturer's recommendations.
- Making unauthorised modifications to this jack.

**INTENDED USE**

For heavy duty truck, agriculture, construction, mining, automotive, and marine applications where lifting is required.

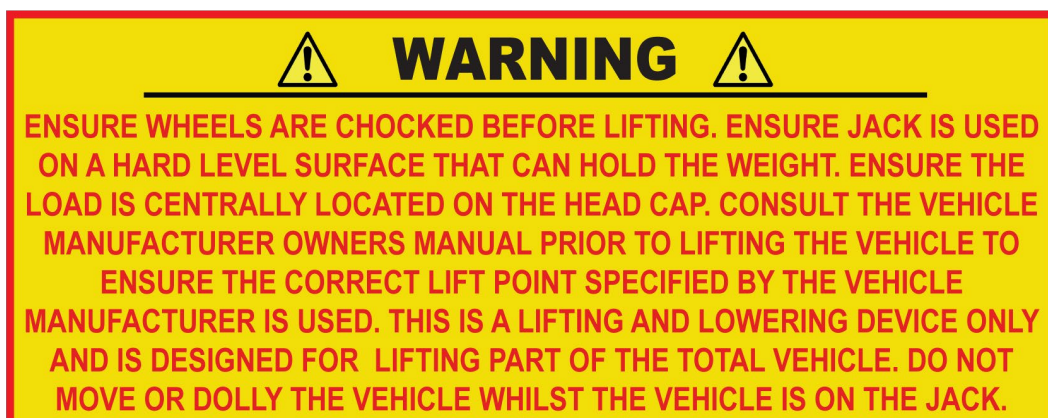

## ASSEMBLY, OPERATION & PREVENTATIVE MAINTENANCE

### 1. FEATURES

The TradeQuip Hydraulic Bottle Jack is designed specifically for lifting and lowering, but not sustaining load. This unit provides enough lifting power for use with most automotive and farm vehicles, heavy duty machinery, industrial construction equipment and more. Its low profile design gets you out of tight situations with ease.

### 2. BEFORE USE

Conduct a thorough visual inspection checking for any abnormal conditions, such as cracked welds, and damaged, loose, or missing parts. Bleed any trapped air from the hydraulic system by performing the air purge procedure below.

#### Bleed Air from Hydraulic System:

During transit the unit may become "air-bound", causing a spongy ram action. To bleed the hydraulic system;

1. Remove the Oil Filler Bung and if required, refill with \*32 Grade hydraulic oil until the oil is lapping the bottom of the Oil Filler Hole then replace the Oil Filler Bung.
2. Start with the Pump Socket Assembly in the horizontal position.
3. Turn the release valve clockwise to the lifting position.
4. With the jack on its base pull the pump socket upwards to the raised position.
5. Invert the jack and push the Pump Socket Assembly back to the horizontal position.
6. Place the jack on its base.
7. Repeat steps 4 to 6 until the Pump Lever feels firm and the lift ram is extending.
8. At this point the Pump Assembly should be bled of air. Follow steps 9 to 10 to purge the Lift Ram
9. Ensure the jack is on its base and make sure the Release Valve is still in raise mode, pump the lift ram to full extension.
10. Pump the Pump Socket Assembly a further ten strokes. The air trapped in the lift ram will vent to the reservoir through the Overstroke Protection Port built into the lift ram barrel positioned at the end of the lift ram stroke.
11. Turn the Release valve to the lowering position.
12. Apply force to the lift ram to the fully retracted position.

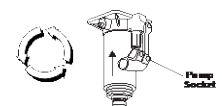
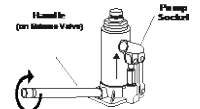
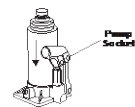
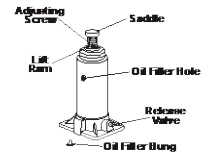

**At this point both the Pump and Lift Ram should be free of air and the Jack ready for operation.**

### 3. OPERATION

Prior to each use always conduct a visual inspection checking for and any abnormal conditions, such as cracked welds, and damaged, loose, or missing parts.

The Jack operates when the release valve is closed, an upward stroke of the jack handle draws hydraulic oil from the reservoir tank into the plunger cavity. A downward stroke of the jack handle releases hydraulic oil into the cylinder, which forces the ram up. This raises the saddle. When the ram reaches its maximum extension, oil is bypassed back into the reservoir to prevent over extended ram and possible damage to the jack. Opening the release valve allows oil to flow back into the reservoir. This releases hydraulic oil pressure on the ram, which results in the lowering of the saddle.

#### To Lift the Vehicle:

1. Set the parking brake in the vehicle.
2. Block the vehicle's wheels for lifting stability. Secure the load to prevent inadvertent shifting and movement.
3. Position the jack near the specified lift point.
4. Refer to the vehicle manufacturer owner's manual to locate approved lifting points on the vehicle. Position the jack so the saddle is centred and will contact the load lifting point firmly
5. Close the release valve by turning it clockwise until it is firmly closed.
6. Before raising the vehicle double check and verify the saddle is centred and also has full contact with the lifting point.
7. Pump the handle to lift until the saddle makes contact with the vehicle. Then continue to pump the jack handle to lift the vehicle to the desired height. Then immediately support the load with the appropriately rated jack support stands before working on the vehicle.

#### To Lower Vehicle:

1. Turn the release valve counter-clockwise to the closed position.
2. Raise load high enough to allow clearance for the jack stands to be removed, then carefully remove jack stands.
3. DO NOT get under or let anyone else under vehicle whilst lowering.
4. Carefully turn the release valve knob SLOWLY counter clockwise to lower vehicle onto the ground.

#### 4. MAINTENANCE

If you use and maintain your equipment properly, it will give you many years of service. Follow the maintenance instructions carefully to keep your equipment in good working condition. Never perform any maintenance on the equipment while it is under a load.

##### Oil Level:

The level of oil should be maintained a minimum of 6mm below filler cap. Top up with quality hydraulic ISO VG32 oil.

**DO NOT** use brake/trans fluid or engine oil.

**Inspection:** Inspect the product for damage, wear, broken or missing parts (eg, pins) and that all components function before each use. Follow lubrication and storage instructions for optimum product performance.

**Binding:** If the product binds while under a load, use equipment with equal or larger load capacity to lower the load safely to the ground. After un-binding clean, lubricate and test that equipment is working properly. Rusty components, dirt, or worn parts can be causes of binding. Clean and lubricate the equipment as indicated in the lubrication section. Test the equipment by lifting without a load.

**Cleaning:** If the moving parts of the equipment are obstructed, use cleaning solvent or another good degreaser to clean the equipment. Remove any existing rust, with a penetrating lubricant.

**Lubrication:** This equipment will not operate safely without proper lubrication. Using the equipment without proper lubrication will result in poor performance and damage to the equipment. Some parts in this equipment are not self-lubricating. After cleaning, lubricate the equipment using a high grade light penetrating oil or lubricating spray.

- Use a good lubricant on all moving parts
- For light duty use, lubricate once a month
- For heavy and constant use, lubrication is recommended every week.
- NEVER use sandpaper or abrasive material on these surfaces.

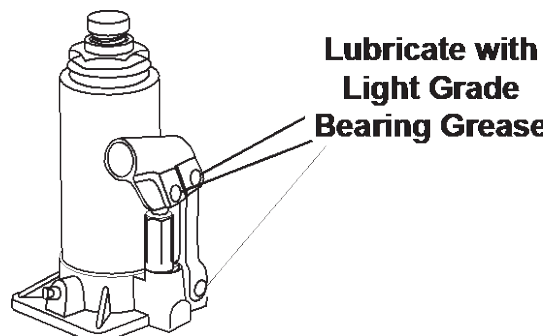

**Rust Prevention:** Check rams and pump plungers on the power unit assemblies daily for any signs of rust or corrosion. Without a load on the equipment extend hydraulic rams to check if signs of rust are visible, clean as needed.

##### Storage:

- Always store the jack with the ram fully retracted
- Ensure the jack handle is in the up position
- Always store in a dry location, preferably indoors



**WARNING - Top up with quality hydraulic ISO VG32 oil.  
DO NOT use brake/trans fluid or engine oil.**

#### 5. SERVICE & REPAIR

Any Bottle Jack found damaged in any way, or found to be worn or operates abnormally should be removed from service until repaired by an authorised service agent. Owners and / or operators should be aware that repair of this product may require specialised equipment and knowledge. Only authorised parts, labels, decals shall be used on this equipment. Annual inspection of the Bottle Jacks is recommended and can be made by an authorised repair facility to ensure that your equipment is in optimum condition and that the equipment has the correct decals and safety labels specified by the manufacturer.

## PARTS LIST

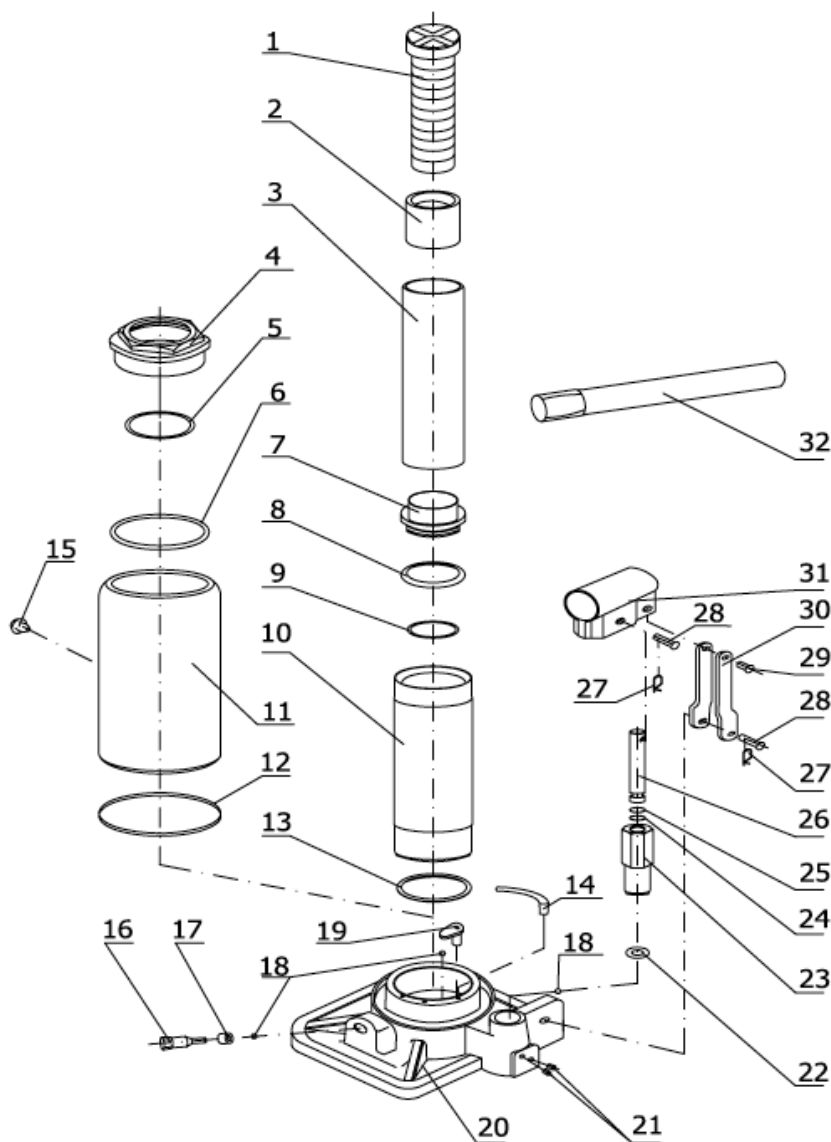

Part #	Description	QTY
1	Adjustable Saddle	1
2	Saddle Socket	1
3	Piston Rod	1
4	Nut	1
5	O-Ring (Nut)	1
6	Seal	1
7	Piston	1
8	Bowl Washer	1
9	O-Ring (Piston)	1
10	Cylinder	1
11	Reservoir	1
12	Reservoir Seal	1
13	Base Plate Washer	1
14	Filter Screen	1
15	Oil Filler Plug	1
16	Release Valve	1
17	Release Valve Seal	1

Part #	Description	QTY
18	Ball 6mm	3
19	Ball Stopper	1
20	Base	1
21	Bolt	2
22	Washer (Pump)	1
23	Pump	1
24	O-Ring (Plunger)	1
25	Back Ring	1
26	Plunger	1
27	R-Pin	1
28	Pin	1
29	Short Pin	2
30	Link Plate	1
31	Handle Socket	2
32	Handle Top	1

## TROUBLESHOOTING

Problem	Symptom	Cause	Conclusion	Solution
Jack will not lift	Pump has resistance but no lift  Pump has no resistance and/or lift ram will not raise	Release valve not tightly closed  Air in hydraulic system  Overload actuated	Bypass through release valve  Air cavitation in pump and/or lift ram  Relief valve needs reset  Higher capacity jack required	Ensure release valve tightly closed  Bleed system  Contact qualified technician for repairs  Select higher capacity jack
Jack will not hold load	Load cannot be sustained, lift ram drops under load  Pump handle rises	Release valve not tightly closed  Damaged main seal  Main check valve obstructed	Bypass through release valve  Replace main ram seals  Replace main check valve ball and reseal valve seat	Ensure release valve tightly closed  Contact qualified technician for repairs
Jack will not lower after unloading	Ram rises after retracting  Release valve pin seized	Reservoir overfilled  Linkages binding	Pump failure due to cavitation caused by excess reservoir level  Dry release valve pin	Drain fluid to proper level  Lubricate release valve with 32grade hydraulic oil
Poor lift performance	Pump has no resistance, lift ram will not raise to full stroke	Fluid level low  Air trapped in system	Fill fluid to correct level  Lift ram raised for extended period causing air ingress to hydraulic system	Fill fluid to correct fluid level and bleed system  With ram fully retracted, remove oil filler plug to let pressurised air escape reinstall oil filler plug then bleed system
Will not lift to full extension	Lift ram has limited stroke, pump loses resistance	Fluid level low	Lift ram raised for extended period causing air ingress to hydraulic system	Fill fluid to correct level then bleed system

## WARRANTY

TradeQuip products have been carefully tested and inspected before shipment and are guaranteed to be free from defective materials and workmanship for a period of 12 months from the date of purchase except where tools are hired out when the guarantee period is ninety days from the date of purchase.

Should the machine develop any fault, please return the complete tool to your nearest authorised warranty repair agent or contact TQB Brands Pty Ltd Warranty team – [warranty@tqbbrands.com.au](mailto:warranty@tqbbrands.com.au).

If upon inspection it is found that the fault occurring is due to defective materials or workmanship, repairs will be carried out free of charge. This guarantee does not apply to normal wear and tear, nor does it cover any damage caused by misuse, careless or unsafe handling, alterations, accident, or repairs attempted or made by any personnel other than the authorised TQB Brands Pty Ltd repair agent.

This guarantee applies in lieu of any other guarantee expressed or implied and variations of its terms are not authorised.

Your TQB Brands Pty Ltd guarantee is not effective unless you can produce upon request a dated receipt or invoice to verify your proof of purchase within the 12 month period.

### Consumer Guarantee

Our goods come with a guarantee that cannot be excluded under the Australian Consumer Law. You are entitled to a replacement or refund for a major failure and compensation for any other reasonably foreseeable loss or damage. You are also entitled to have the goods repaired or replaced if the goods fail to be of acceptable quality and the failure does not amount to a major failure.



All images and illustrations shown are for reference purposes only. All information, specifications and illustrations in this manual are based on the latest information available at the time of publication and are subject to change without notice. The information in this manual is periodically revised to ensure the latest information is included. Download the latest version of this manual and other related technical documentation from [www.tqbbrands.com.au](http://www.tqbbrands.com.au).