



## OWNER'S MANUAL

PRODUCT CODE: 6053 and 6054

### MOBILE PARTS BIN STORAGE SYSTEMS



Code	Dimensions	Warranty	Wheel Size	Load Capacity	Weight
6053	860x410x940mm	12months	75mm	60kg	30kg
6054	860x410x1780mm	12months	75mm	150kg	49.6kg

**WARNING****IMPORTANT: READ ALL INSTRUCTIONS BEFORE USE****WARNING**

The instructions and warnings contained in this manual should be read and understood before using or operating this equipment. Do not allow anyone to use or operate this equipment until they have read this manual and have developed a thorough understanding of how this equipment works. Failure to observe any of the instructions contained in the manual could result in severe personal injury to the user or bystanders, or cause damage to the equipment and property. Keep this manual in a convenient and safe place for future reference.

Whilst every effort has been made to ensure accuracy of information contained in this manual, the TQB Brands Pty Ltd policy of continuous improvement determines the right to make modifications without prior warning.

**CONTENT**

WARNING .....	2
CONTENT .....	2
SAFETY INSTRUCTIONS .....	3
ASSEMBLY, OPERATION, PREVENTITIVE MAINTENANCE .....	3
PARTS LIST .....	8
WARRANTY .....	9

## SAFETY INSTRUCTIONS



### SAFETY OPERATING INSTRUCTIONS

- Do not exceed the products rated maximum load capacity.
- Always distribute objects evenly on the Mobile Parts Bin Trolley. Uneven weight distribution could cause tipping.
- Do not lean or climb onto the Mobile Parts Bin Trolley.
- Only use this device for the purpose for which it has been designed.
- Do not modify any component of this equipment.
- When servicing, use only Tradequip identical replacement parts. Use of any other parts will void the warranty.
- Only use on a flat surface capable of supporting the Mobile Parts Bin Trolley and its rated maximum capacity load. It is easy to lose control of the Mobile Parts Bin Trolley if attempting to pull a load on a sloping or uneven surface.
- Use the right product for the job. There are certain applications for which the Mobile Parts Bin Trolley was designed. Do not modify the Mobile Parts Bin Trolley and do not use the Mobile Parts Bin Trolley for a purpose for which it was not intended.

## ASSEMBLY, OPERATION, PREVENTITIVE MAINTENANCE

### 1. FEATURES

The Tradequip Mobile Parts Bin Storage Systems keep the tools and parts you need for the job organised and easily accessible in its convenient mobile design. With assorted small and large storage bins, this portable floor rack helps organize and store countless parts. Features include four smooth rolling swivel castors for easy manoeuvrability around your work area and a glossy powder coat finish for durability. Powder coated steel racks with robust composite storage bins evenly spread across multiple shelves. Mounted on heavy-duty castors (two lockable) for mobility. unit can hold up to a maximum weight of 60kg - 150kg (Model dependant) evenly spread across the bins. A great mobile tool storage for any garage or workshop, this piece of kit is widely used for collecting and storing parts and/or tools when servicing vehicles and machinery etc.

### 2. ASSEMBLY

**Unpacking:** after removing the packing material, make sure the product is in perfect condition and that there are no visible damaged parts. The packaging materials (Polyethylene bags, polystyrene etc.), should be disposed of responsibly in an appropriate refuse collection container. These materials must not be left within the reach of children as they are potential sources of danger.

**Assemble the Trolley:**

1. Take the four uprights and insert the four castors into the bottom of each. (See fig.1) Ensure the castors are fully seated.
2. Assemble the front and back frames.
3. Take two of the uprights with locking castors and insert long beam between the two uprights at the top and bottom. (See fig.2) Ensure the beams are the correct way up (See fig.2A/B) and seated correctly, use a soft faced mallet to tap the beams home.
4. Repeat process for the other two uprights using the non-locking castors.
5. Attach the front and rear frame together using the smaller side braces with the double tabs, insert at the top and bottom of the frames (See fig.3A). Ensure again they are the correct way up and that the locking castors are at the front.
6. Between the two uprights, install the centre braces (single tab) half way up the frames. see fig.3B.
7. **6054 only** - As well as the side braces attach front and rear beam (single tab) exactly half way up the frame, front and back (See fig.3B).
8. Insert the remaining cross beams in the frame using fig.4 and fig.5 to space them out correctly. Ensure the beams are the correct way around to hold the wire shelves (See fig.4, fig.5). As before use a soft faced mallet to tap the beams into place.
9. Starting at the bottom place the wire shelves into the frame ensuring the shelves for the larger bins are at the bottom and the shelves for the smaller bins are at the top.
10. Place the flat wire shelf on the top. the storage system is now ready to use.

Fig.1

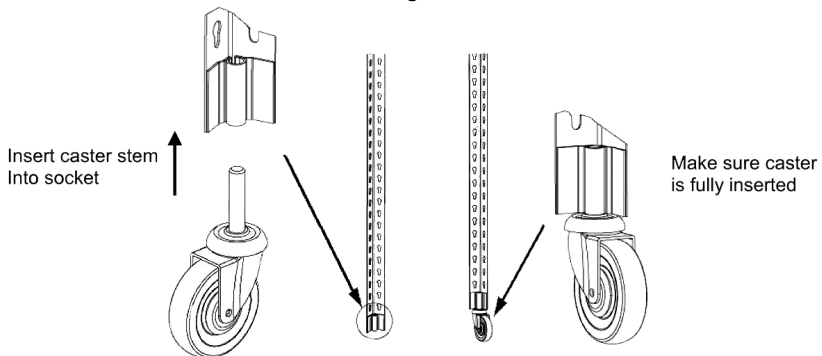

Fig.2

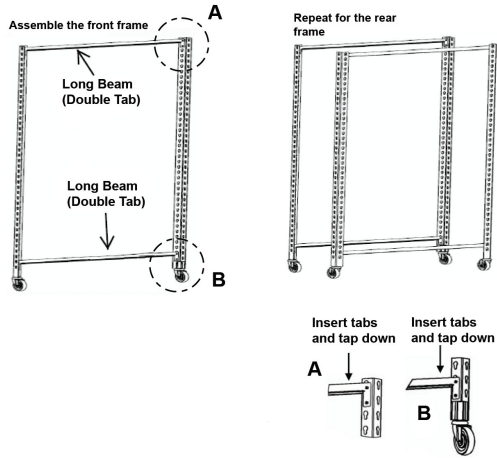

Fig.3

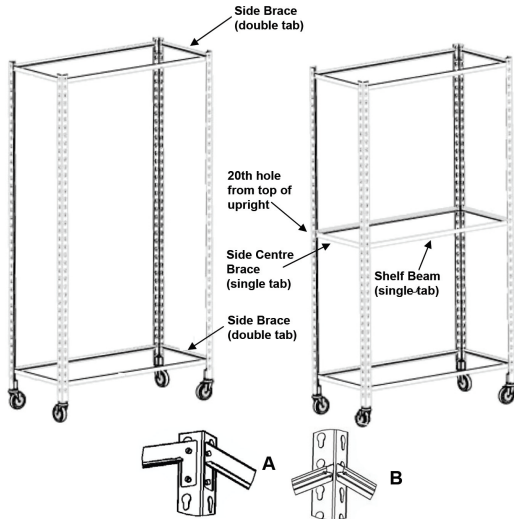

Fig.4

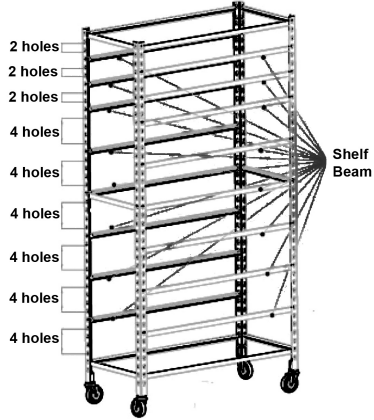

Fig.5

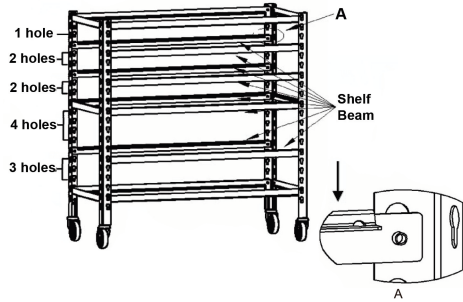
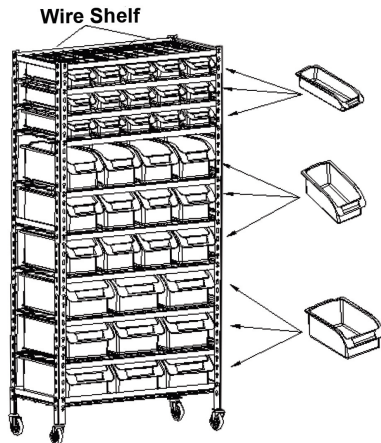
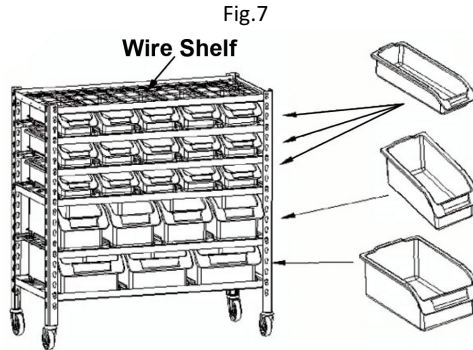

Fig.6





*Your Mobile Parts Bin Trolley is ready for use.*

**Warning** - Do not exceed the product's rated maximum load capacity.

### 3. BEFORE USE

Prior to each use conduct a visual inspection by checking for abnormal conditions, such as cracked joints and damaged, loose, or missing parts.

### 4. STORAGE

This Mobile Parts Bin Storage System should always be stored in a dry location on a level surface.

### 5. MAINTENANCE

Inspect the general condition of the Mobile Parts Bin Storage System checking:

- for loose hardware
- misalignment of binding or parts, cracked, bent, or broken parts, and
- any other condition that may affect the safe operation.
- Clean the Mobile Parts Bin Storage System after each use. Ensure dirt, oil, grease and debris are cleaned off after each use.

### 6. SERVICE & REPAIR

Any Mobile Parts Bin Storage System found damaged in any way, or found to be worn or operates abnormally should be removed from service until repaired by an authorised service agent. Owners and / or operators should be aware that repair of this product may require specialised equipment and knowledge. Only authorised parts, labels, decals shall be used on this equipment. Annual inspection is recommended and can be made by an authorised repair facility to ensure that your equipment is in optimum condition and that the equipment has the correct decals and safety labels specified by the manufacturer.

## PARTS LIST

Description	6053 qty	6054 qty
Swivel Castor	2	2
Swivel Castor - Lockable Brake	2	2
Upright	4	4
Beam - Double Tab	4	4
Side Brace – Double Tab	4	4
Shelf Beam – Single Tab	8	16
Side Centre Brace – Single Tab	2	2
Wire Shelf – Small Bin	1	3
Wire Shelf – Medium Bin	1	3
Wire Shelf – Large Bin	3	3
Wire Shelf – Top	1	1
Small Parts Bin	3	9
Medium Parts Bin	4	12
Large Parts Bin	15	15



## WARRANTY

Tradequip products have been carefully tested and inspected before shipment and are guaranteed to be free from defective materials and workmanship for a period of 12 months from the date of purchase except where tools are hired out when the guarantee period is ninety days from the date of purchase.

Should this equipment develop any fault, please return the complete tool to your nearest authorised warranty repair agent or contact TQB Brands Pty Ltd Warranty team – [warranty@tqbbrands.com.au](mailto:warranty@tqbbrands.com.au).

If upon inspection it is found that the fault occurring is due to defective materials or workmanship, repairs will be carried out free of charge. This guarantee does not apply to normal wear and tear, nor does it cover any damage caused by misuse, careless or unsafe handling, alterations, accident, or repairs attempted or made by any personnel other than the authorised TQB Brands Pty Ltd repair agent.

This guarantee applies in lieu of any other guarantee expressed or implied and variations of its terms are not authorised.

Your TQB Brands Pty Ltd guarantee is not effective unless you can produce upon request a dated receipt or invoice to verify your proof of purchase within the 12month period.

### **Consumer Guarantee**

Our goods come with a guarantee that cannot be excluded under the Australian Consumer aw. You are entitled to a replacement or refund for a major failure and compensation for any other reasonably foreseeable loss or damage. You are also entitled to have the goods repaired or replaced if the goods fail to be of acceptable quality and the failure does not amount to a major failure.



TQB Brands Pty Ltd

1/40 Metrolink Circuit  
Campbellfield  
Victoria  
3061

[sales@tqbbrands.com.au](mailto:sales@tqbbrands.com.au)