

Superior quality since
1984



Owners Manual

7,000KG AUXILIARY STAND

BORUM

INDUSTRIAL WORKSHOP EQUIPMENT

**INDUSTRIAL
QUALITY**



Specifications

- Safe Working Capacity: 7,000kg
- Maximum Height: 1905mm
- Minimum Height: 1295mm
- 3 saddle options: 90mm, 120mm, up to 150mm \varnothing
- Adjustable Pin Heights: 8
- Base Dimensions: 300x300x300mm
- Nett Weight: 65kg
- Carton: 1130 x 370 x 320mm
- Weight: 68kg

About the Borum brand

Our **"heavy duty commercial"** range of Borum Industrial equipment has been manufactured to exacting standards for the past **34 years**. We specify industrial quality components and design to ensure a long and durable working life in **commercial transport, mining, earthmoving and railway** environments. Our Borum Industrial range of equipment is focused on achieving superior professional standards, reliability, quality, and are covered by a **12 month trade use warranty**.

WARNING INFORMATION



IMPORTANT: READ ALL INSTRUCTIONS BEFORE USE

WARNING

The instructions and warnings contained in this manual should be read and understood before using or operating this equipment. Do not allow anyone to use or operate this equipment until they have read this manual and have developed a thorough understanding of how this equipment works. Failure to observe any of the instructions contained in the manual could result in severe personal injury to the user or bystanders, or cause damage to the equipment and property. Keep this manual in a convenient and safe place for future reference.

The warnings, cautions and instructions discussed in this instruction manual cannot cover all possible conditions and situations that may occur. It must be understood by the operator that common sense and caution are factors which cannot be built into this product, but must be supplied by the operator.

Whilst every effort has been made to ensure accuracy of information contained in this manual, the Borum policy of continuous improvement determines the right to make modifications without prior warning.

CONTENTS

WARNING INFORMATION.....	1
STANDARD OPERATING PROCEDURE	2
ASSEMBLY, OPERATION, PREVENTITIVE MAINTENANCE.....	3
PARTS DIAGRAM & PARTS LIST	6
PRODUCT INFORMATION TIPS.....	7
WARRANTY.....	8

STANDARD OPERATING PROCEDURE

DO NOT use this machine unless you have been trained and assessed to a competent level in its safe use and operation, and have been given permission to use this



Safety glasses must be worn when operating this equipment



Long loose hair must be contained when operating this equipment



Safety footwear must be worn when operating this equipment



Close fitting/protective clothing must be worn when operating this equipment

PRE-OPERATIONAL SAFETY CHECKS

1. The maximum load is 7,000kg. DO NOT exceed this rated capacity.
2. Study, understand, and follow all instructions before operating this support stand.
3. Retain these instructions for future reference.
4. The equipment described in this manual could be potentially dangerous if improperly or carelessly operated. For the protection of all persons and equipment, only competently trained operators who are critically aware of the proper operating procedures, potential dangers, and specific application of this equipment should be allowed to use this equipment at any time.
5. Because of potential hazards associated with this type of equipment, no alterations shall be made to this product.
6. Failure to heed all warnings contained in this manual may result in personal injury and/or property damage.
7. All warranties applicable to this equipment are contingent on strict adherence to the operation and maintenance procedures in this manual.

OPERATIONAL SAFETY CHECKS

1. Do not exceed rated capacity. Overloading can cause damage to or failure of the stand.
2. Use stands on hard level surface capable of sustaining the load.
3. Always centre load on saddle.
4. Use only matching support stands when used in multiples.
5. Support only on the areas of a vehicle as specified by the vehicle manufacturer.
6. Only use attachments and/or adaptors supplied by the manufacturer.
7. Use wheel chocks and/or other blocking device on opposing wheels before using this support stand.
8. Do not use if damaged in any way.
9. Failure to heed all warnings contained in this manual may result in personal injury and/or property damage.

ASSEMBLY, OPERATION, PREVENTITIVE MAINTENANCE

1. FEATURES & MODELS

The **BORUM Industrial** Heavy Duty Auxiliary Stand is a reinforced pin style vehicle stand with a heavy duty design and support bracing system to sustain heavy vehicle loads up to 7,000kg. It's adjustable to match the job with a 1255mm minimum lift height and 1905mm maximum lift height. Featuring Heavy-Duty Industrial design, this tough stand is ideal for use under 2 post and 4 post vehicle lifts. With adjustable height increments, 3 choices of saddle attachments, and a stable tripod design, the feet (with base plates) securely hold this auxiliary stand in place when the spring loaded swivel castor wheels are under load. This heavy duty stand is mobile when needed and stable under load, so its a very handy peice of equipment when working under a vehicle lift. This tripod design ensures complete stability, even when your workshop floor is not perfectly flat. The Auxiliary Stand also has a spring loaded support beam.

2. BEFORE USE

- Prior to each use conduct a visual inspection checking for abnormal conditions, such as cracked welds, metal fatigue, and damaged, loose, or missing parts.

3. OPERATION

1. Do not exceed rated capacity. Overloading can cause damage to or failure of the stand. Use stands on hard level surface capable of sustaining the load.
2. Use only on a solid surface that will sustain the load eg. concrete.
3. Locate saddle at vehicle manufacturer designated support points. Always consult the vehicle lifting guide for the proper lifting points on any vehicle. These guides are available from the vehicle manufacturers.
4. Always place the load in the centre of the saddle only.
5. Always use a minimum of four stands to support and stabilize a vehicle, and a minimum of two additional stands for each additional axle assembly, before commencing repairs.
6. Do not apply horizontal forces or large torque loads to the vehicle whilst supported by Borum Auxiliary Support Stands.
7. Do not move or rock the vehicle whilst supported by Borum Auxiliary Support Stands.
8. Ensure that the support stands are stable and the vehicle is evenly supported before lowering onto the support stands.
9. Always carefully lower vehicle onto all support stands simultaneously.
10. Only use attachments, restraints or adaptors supplied by the manufacturer.
11. Always adjust height of support stand up to load with the extension tube all the way down first. Then raise the extension tube up to highest available pin setting.
12. Always ensure that locking pin is fully inserted into holes through entire base frame and that the hitch pin is securely retained on the other side.
13. The centre extension tube is spring loaded to assist in raising tube to desired height.
14. Use caution when pulling hitch pin. Built up spring force may raise centre tube suddenly.



Positioning Load

1. Locate vehicle manufacturer designated support points. Always consult the vehicle lifting guide for the proper lifting points on any vehicle.
2. Carefully select the appropriate saddle shape to best support vehicle load on designated support position.
3. Carefully position support stand, so that load is centered on the support stand saddle when load is lowered.
4. Adjust saddle height by removing the hitch pin and pulling out the locking pin, to allow the spring loaded centre extension tube to raise itself to the highest available position.
5. Ensure that the locking pin holes are aligned, then insert locking pin into the extension tube far enough to reinstall the hitch pin into the locking pin hole on the other side.
6. Ensure all support stands are adjusted to evenly support the vehicle and check that they have all pins securely locked in place.
7. Slowly lower the vehicle onto the support stands.
8. Check to ensure vehicle is secured before working on, around or under.
9. Always use wheel chocks on all un-lifted wheels in both directions to prevent inadvertent movement.

Removing and Lowering Load

1. **WARNING:** Clear all tools and personnel.
2. With a suitable lifting device, raise vehicle load clear of the support stands.
3. Carefully release the locking hitch pin and remove the locking pin. Use caution when pulling the locking pin as built up spring force may raise centre tube suddenly.
4. Push down on extension tube to slide it down to its lowest position.
5. Ensure that the locking pin holes are aligned, then insert locking pin into the extension tube far enough to reinstall the hitch pin into the locking pin hole on the other side.
6. Carefully remove the support stand, then carefully lower vehicle with the lifting device

4. MAINTENANCE

This product shall be maintained in accordance with the following Maintenance instructions.

1. Visual inspection shall be made before each use of this unit by checking for abnormal conditions such as cracked welds, leaks, and damaged, loose, or missing parts.
2. Other inspections shall be made per operating instructions above.
3. Each unit shall be inspected immediately if the lift is believed to have been subjected to an abnormal load or shock. It is recommended that this inspection be made by a manufacturer's or supplier's authorised repair facility.
4. Owners and/or operators should be aware that repair of this equipment may require specialized knowledge and facilities. It is recommended that an annual inspection of this unit be made by a manufacturer's or supplier's authorized repair facility and that any defective parts, decals, or warning labels be replaced with manufacturers or supplier's specified parts. A list of Authorized repair facilities is available from the manufacturer or supplier.
5. Any unit that appears to be damaged in any way, is found to be worn, or operates abnormally shall be removed from service until repaired. It is recommended that necessary repairs be made by the manufacturers or supplier's authorised repair facility if repairs are permitted by the manufacturer or supplier.

5. INSPECTION

- Prior to each use conduct a visual inspection checking for abnormal conditions, such as cracked welds, metal fatigue, and damaged, loose, or missing parts.
- Owners and /or operators should be aware that repair of this product may require specialised equipment and knowledge (refer to maintenance section).

6. STORAGE

This Borum Auxiliary Stand should always be stored in a dry location on a level surface.

7. SERVICE & REPAIR

Any Borum Industrial Auxiliary Stand found damaged in any way, or found to be worn or operates abnormally should be removed from service until repaired by an authorised service agent. Owners and / or operators should be aware that repair of this product may require specialised equipment and knowledge. Only authorised parts, labels, decals shall be used on this equipment. Annual inspection of the auxiliary stand is recommended and can be made by an authorised repair facility to ensure that your equipment is in optimum condition and that the equipment has the correct decals and safety labels specified by the manufacturer.

PARTS DIAGRAM & PARTS LIST

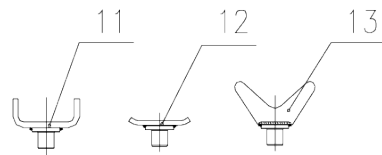
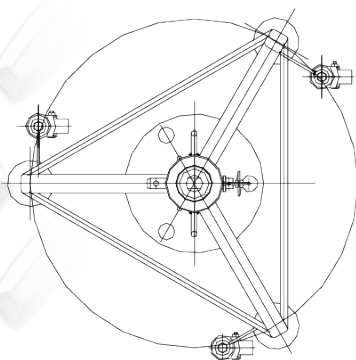
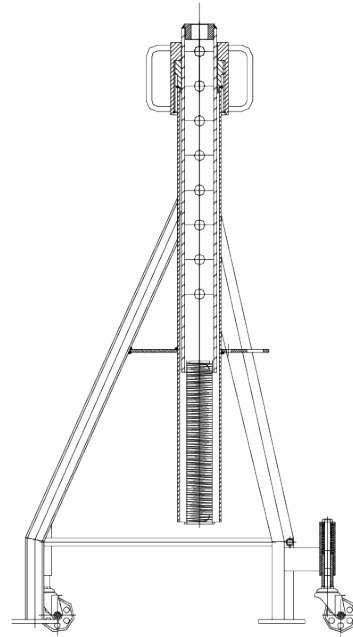
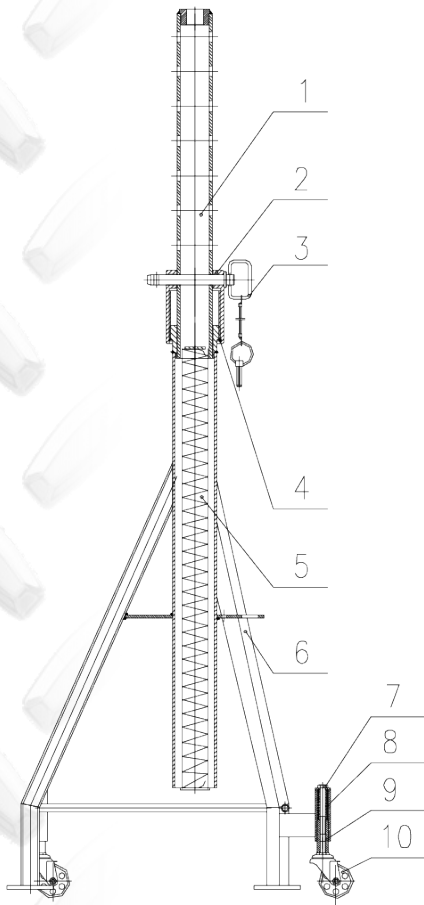

Part	Description	QTY
1	Slider Tube	1
2	Lift Rod	1
3	Hitch Pin Assembly	1
4	Ring Snap	1
5	Spring	1
6	Jack Stand Base Assembly	1
7	Bolt	3

Part	Description	QTY
8	Spring	3
9	Link Tube	3
10	Wheel Assembly	3
11	"U" Head	1
12	"U" Head	1
13	"V" Head	1

PRODUCT INFORMATION TIPS

PRODUCT INFORMATION

How to extend the life of your Vehicle Chassis Stand

9 Top Tips

to extend the life of your TQB BRANDS Borum Heavy Industrial Vehicle Auxiliary Stand BAUXS7T

- 1** Regularly lubricate all spring-loaded castors and wheels for ease of movement.



- 2** Regularly lubricate the Centre Column.

Lubrication of the centre column on your Borum BAUXS7T Auxiliary Stand allows for smooth height positioning. We recommend a light application of a general-purpose grease.

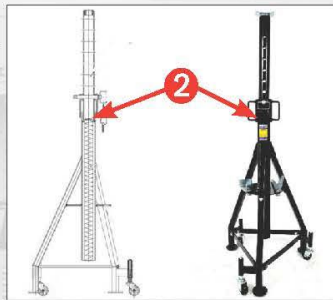

- 3** Borum BAUXS7T Auxiliary Stands come with a solid locking pin and safety latch attached to the body with a cable.

Once the correct height is reached, extend the spring-loaded centre column then insert the locking pin and safety latch prior to lowering a vehicle onto the stand or placing under a drivetrain or chassis part for support.



- 4** Borum BAUXS7T Auxiliary Stands must be used on a smooth horizontal surface.

Pin Type Vehicle Chassis Stands rely on a smooth flat horizontal surface to remain stable and minimise lateral forces. When raising a vehicle from an axle to place on stands the correct balanced lifting point must be used to prevent tipping or load collapse.

WARNING: Never used to support and/or stabilise a vehicle that is raised by a 2 or 4 post hoist or the Ground Lift. Borum BAUXS7T stands should always be used in pairs. Always use a minimum of four stands to support and stabilise a vehicle, and a minimum of two additional stands for each additional axle assembly, before commencing repairs. Consult the vehicle manufacturer for lifting and vehicle stand loading points.



- 5** Securing the vehicle.

A vehicle must have the park brake applied and the wheels chocked prior to raising to place a vehicle stand. Borum Pin Type Vehicle stands can only be used to support one end of a vehicle. The stability of a vehicle on stands is critical to the safety of personnel conducting repairs.

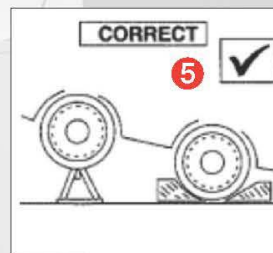

- 6** Correct Placement.

Borum BAUXS7T Auxiliary Stands come with a choice of three load adaptor heads that should always have the load cradle centrally positioned on the vehicle lift or drivetrain support points. Consult the vehicle manufacturer for lifting and vehicle stand loading points prior to elevating or supporting a vehicle or supporting suspended drivetrain parts.

- The V Head is best used to support Rear Cross Beams and items such as Tail Shafts, Exhausts, Axles and provide support while other components are removed for repair.
- The Shallow sided V head is suitable for Cross Member support while removing Gearboxes and supporting Engines in situ during Drivetrain Repairs.
- The Deep sided V head is suitable for Chassis support allowing Suspension Repairs, Air Brake assembly and Fuel tank removal.



- 7** Hazards and Obstructions.

All wheeled TQB Brands equipment must be used on smooth surface free of cracks, crevices and tripping hazards that can foul the wheels during operation or relocation.

- 8** Personal Safety.

No persons should be in a vehicle that is supported by Vehicle Stands. Engine must be turned off. Testing of Drivetrain or running of Engines whilst a vehicle is on stands can create vibration and potential tipping of the vehicle.

- 9** Read the user Manual thoroughly and keep a copy easily accessible.

The user manuals are important to the initial set up and ongoing maintenance and come with each Vehicle Stand, they are also downloadable from our webpage at www.tqbbrands.com.au



WARRANTY

BORUM Industrial products have been carefully tested and inspected before shipment and are guaranteed to be free from defective materials and workmanship for a period of 12 months from the date of purchase except where tools are hired out when the guarantee period is ninety days from the date of purchase.

Should this piece of equipment develop any fault, please return the complete tool to your nearest authorised warranty repair agent or contact TQB Brands Pty Ltd Warranty team – warranty@tqbbrands.com.au.

If upon inspection it is found that the fault occurring is due to defective materials or workmanship, repairs will be carried out free of charge. This guarantee does not apply to normal wear and tear, nor does it cover any damage caused by misuse, careless or unsafe handling, alterations, accident, or repairs attempted or made by any personnel other than the authorised TQB Brands Pty Ltd repair agent.

This guarantee applies in lieu of any other guarantee expressed or implied and variations of its terms are not authorised.

Your TQB Brands Pty Ltd guarantee is not effective unless you can produce upon request a dated receipt or invoice to verify your proof of purchase within the 12month period.

Consumer Guarantee

Our goods come with a guarantee that cannot be excluded under the Australian Consumer Law. You are entitled to a replacement or refund for a major failure and compensation for any other reasonably foreseeable loss or damage. You are also entitled to have the goods repaired or replaced if the goods fail to be of acceptable quality and the failure does not amount to a major failure.



All images and illustrations shown are for reference purposes only. All information, specifications and illustrations in this manual are based on the latest information available at the time of publication and are subject to change without notice. The information in this manual is periodically revised to ensure the latest information is included. Download the latest version of this manual and other related technical documentation from www.tqbbrands.com.au