

Owners Manual

Product Code: TQBJ12TA

**MADE FOR THE
TRADE**

TQ TRADEQUIP
the trusted brand in equipment

**AIR/HYDRAULIC
BOTTLE JACK**



Specifications:

- Safe Working Capacity: 12,000kg
- Minimum Height: 260mm
- Maximum Height: 510mm
- Hydraulic Stroke: 170mm
- Screw Extension Height: 80mm
- Operating Air Pressure: 110-125psi
- Air Fitting: 1/4"
- Carton: 250x180x270mm
- Gross Weight: 12.75kg

About the TradeQuip brand

The 'TradeQuip' brand of workshop equipment, is designed for use in a demanding workshop environment by professional users. With proven and trusted "Made for the Trade" reliability, 'TradeQuip' branded products offer the very best in performance for an affordable price. All backed by a 1 year trade guarantee across 1,000+ distributors Australia wide.

TQ TRADEQUIP
the trusted brand in equipment

TQPRO
Trusted by serious professionals

BORUM
INDUSTRIAL WORKSHOP EQUIPMENT

WARNING INFORMATION**IMPORTANT: READ ALL INSTRUCTIONS BEFORE USE****WARNING**

The instructions and warnings contained in this manual should be read and understood before using or operating this equipment. Do not allow anyone to use or operate this equipment until they have read this manual and have developed a thorough understanding of how this equipment works. Failure to observe any of the instructions contained in the manual could result in severe personal injury to the user or bystanders, or cause damage to the equipment and property. Keep this manual in a convenient and safe place for future reference.

Whilst every effort has been made to ensure accuracy of information contained in this manual, the TradeQuip policy of continuous improvement determines the right to make modifications without prior warning.

CONTENT

WARNING INFORMATION	2
CONTENT	2
ASSEMBLY, OPERATION & PREVENTATIVE MAINTENANCE	4
PARTS LIST	6
TROUBLESHOOTING	7
WARRANTY	7

STANDARD OPERATING PROCEDURE

DO NOT use this machine unless you have been trained and assessed to a competent level in its safe use and operation, and have been given permission to use this



Safety glasses must be worn when operating this equipment



Long loose hair must be contained when operating this equipment



Safety footwear must be worn when operating this equipment



Close fitting/protective clothing must be worn when operating this equipment



Rings and jewellery must not be worn when operating this equipment

PRE-OPERATIONAL SAFETY CHECKS

- Check vehicle owner's manual for correct vehicle weight - DO NOT exceed the Bottle Jacks rated safe working capacity.
- Use only as specified by the manufacturer.
- The Bottle Jack is a lifting and lowering device only. Immediately after lifting, support the vehicle with appropriate Jack Stands.
- Ensure that each stand is securely located under a strong point on the vehicle - consult vehicles owner's manual for guidance.
- Use only on a hard, level surface.
- Prior to lifting a vehicle, apply the emergency park brake.
- Securely chock wheels remaining on the ground.
- Centre the load prior to lifting.
- **NEVER** attempt to move the load while on the jack. The jack must only be used in a static position for lifting and lowering loads. Ensure that the load remains stable at all times.
- For your safety, do not modify or alter this Bottle Jack.
- **NEVER** use the Bottle Jack if damaged, any suspect parts are noted or it has been subjected to a shock load.
- When servicing, use only TradeQuip identical replacement parts. Use of any other parts will void the warranty.
- **NEVER** use brake fluid or any other improper fluid and avoid mixing different types of oil when adding hydraulic oil. Only a good quality hydraulic jack oil can be used.
- Use the right product for the job. There are certain applications for which the Bottle Jack was designed. Do not modify the Bottle Jack and do not use the Bottle Jack for a purpose for which it was not intended.

INTENDED USE

For heavy duty truck, agriculture, construction, mining, mobile home, oil field, automotive, and marine applications where lifting is required.



WARNING



ENSURE WHEELS ARE CHOCKED BEFORE LIFTING. ENSURE JACK IS USED ON A HARD LEVEL SURFACE THAT CAN HOLD THE WEIGHT. ENSURE THE LOAD IS CENTRALLY LOCATED ON THE HEAD CAP. CONSULT THE VEHICLE MANUFACTURER OWNERS MANUAL PRIOR TO LIFTING THE VEHICLE TO ENSURE THE CORRECT LIFT POINT SPECIFIED BY THE VEHICLE MANUFACTURER IS USED. THIS IS A LIFTING AND LOWERING DEVICE ONLY AND IS DESIGNED FOR LIFTING PART OF THE TOTAL VEHICLE. DO NOT MOVE OR DOLLY THE VEHICLE WHILST THE VEHICLE IS ON THE JACK.

ASSEMBLY, OPERATION & PREVENTATIVE MAINTENANCE

1. FEATURES

The TradeQuip Air Actuated Hydraulic Bottle Jack is designed to operate either manually or pneumatically for lifting and lowering, but not sustaining load. This 12,000kg Heavy-Duty Air/Hydraulic Bottle Jack is the perfect choice for a wide variety of uses. The power of air makes it easy to lift farm vehicles, trucks, lawn mowers, heavy equipment and other large loads. The manual function allows for normal operation anywhere, even without an air supply.

2. BEFORE USE

Conduct a thorough visual inspection checking for any abnormal conditions, such as cracked welds, and damaged, loose, or missing parts.

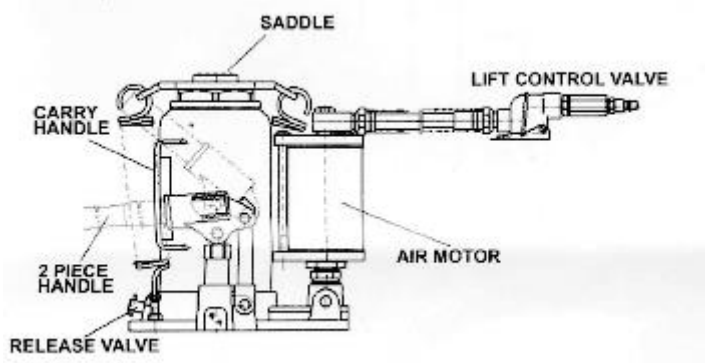

1. Verify that the product and the application are compatible.
2. Pour a teaspoon of good quality air tool lubricant into the air supply inlet of the lift control valve. Connect to air supply and operate for 3 seconds to evenly distribute lubricant.
3. Check to ensure that the pump operates smoothly before putting into service. Replace worn or damaged parts and assemblies with manufacturer approved parts only.
4. This product is fitted with a standard 1/4" NPT air fitting. To change the fitting install a 1/4" NPT fitting of your choice, ensure the thread tape or compound is used to seal the connection.

3. OPERATION

Prior to each use always conduct a visual inspection checking for and any abnormal conditions, such as cracked welds, and damaged, loose, or missing parts.

Raising the Jack:

1. Block the vehicle's wheels for lifting stability. Secure the load to prevent inadvertent shifting and movement.
2. Position the jack near desired lift point.
3. Set the parking brake in the vehicle.
4. Refer to the vehicle manufacturer owner's manual to locate approved lifting points on the vehicle. Position the jack so the saddle is centred and will contact the load lifting point firmly
5. Assemble the handle; ensure that spring clips align with slots.
6. Close the release valve by turning it clockwise until it is firmly closed.
7. Insert and secure the handle into handle sleeve. Pump handle or squeeze the lift control valve until the saddle contacts load. To end air operation simply release the grip on the lift control valve.
8. Raise load to the desired height, then immediately transfer the load to appropriately rated jack stands.

WARNING

Never wire, clamp or otherwise disable the lift control valve to function by any means other than by using the operator's hand. Use the handle provided with this product or an authorised replacement handle to ensure proper release valve operation. Do not use extensions on the air hose or on the operating handle.

To Lower Vehicle:

1. Raise load high enough to allow clearance for the jack stands to be removed, then carefully remove jack stands.
2. Insert handle release valve and slowly turn handle counter clockwise, no more than 1/2 a turn.
3. Grasp the handle firmly with both hands. Securely hold on to the jack handle so your hands do not slip and ensure the load does not rapidly lower.
4. (Do not allow bystanders around the jack or under the load when lowering the jack).

4. MAINTENANCE

If you use and maintain your equipment properly, it will give you many years of service. Follow the maintenance instructions carefully to keep your equipment in good working condition. Never perform any maintenance on the equipment while it is under a load.

Inspection: Inspect the product for damage, wear, broken or missing parts (eg: pins) and that all components function before each use. Follow lubrication and storage instructions for optimum product performance. Ensure all moving parts are clear of dirt and debris.

Cleaning: If the moving parts of the equipment are obstructed, use cleaning solvent or another good degreaser to clean the equipment. Remove any existing rust, with a penetrating lubricant.

Lubrication: This equipment will not operate safely without proper lubrication. Using the equipment without proper lubrication will result in poor performance and damage to the equipment. A coating of light lubricating oil to pivot points, axles and hinges will help to prevent rust. Periodically check the pump piston and ram for signs of rust or corrosion. Clean as needed and wipe with an oily cloth.

NEVER USE SANDPAPER OR ABRASIVE MATERIAL ON THESE SURFACES.

To Add Jack Oil:

NEVER USE BRAKE FLUID, TURBINE OIL, TRANSMISSION FLUID, MOTOR OIL OR GLYCERIN. IMPROPER FLUID WILL CAUSE PREMATURE FAILURE OF THE JACK AND THE POTENTIAL FOR SUDDEN OR IMMEDIATE LOSS OF LOAD

1. With saddle fully lowered and pump piston fully depressed, set jack in its upright level position.
2. Remove oil filler plug.
3. Fill until oil is level with the filler plug hole, reinstall oil filler plug.

Replace Jack Oil:

For best performance and longest life, replace the complete fluid supply at least once per year.

1. With the saddle fully lowered and pump piston fully depressed, remove the oil filler plug.
2. Lay jack on its side and drain the fluid into a suitable container.
3. Fill the oil case until oil level is just beneath the lower rim. KEEP DIRT AND OTHER MATERIAL CLEAR WHEN POURING.
4. Replace oil plug.
5. Perform air purge procedure.

5. SERVICE & REPAIR

Any Bottle Jack found damaged in any way, or found to be worn or operates abnormally should be removed from service until repaired by an authorised service agent. Owners and / or operators should be aware that repair of this product may require specialised equipment and knowledge. Only authorised parts, labels, decals shall be used on this equipment. Annual inspection of the Bottle Jacks is recommended and can be made by an authorised repair facility to ensure that your equipment is in optimum condition and that the equipment has the correct decals and safety labels specified by the manufacturer.

PARTS LIST

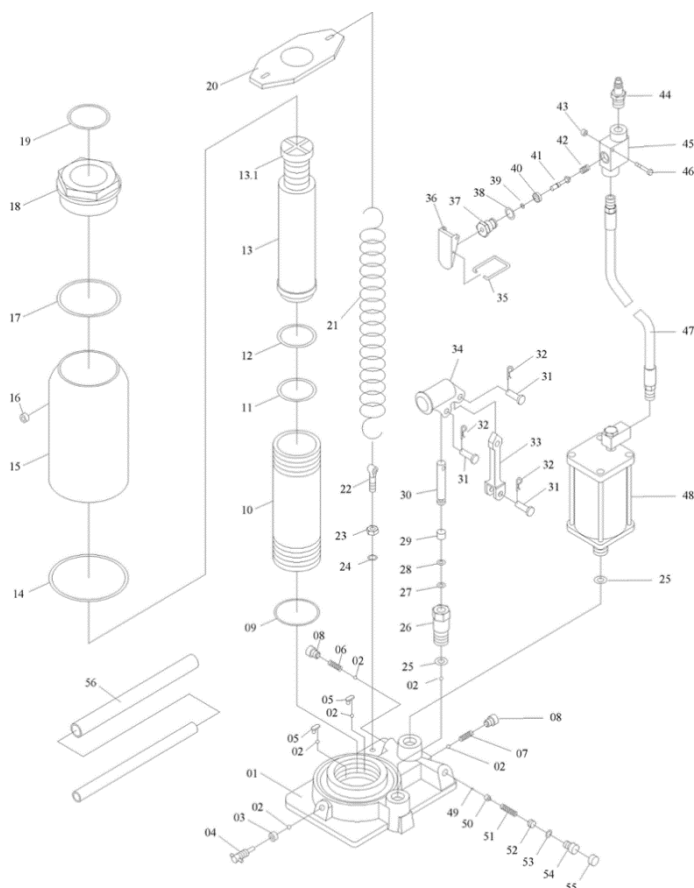

Part	Description	Qty
1	Base	1
2	Ball 1/4"	6
3	Seal	1
4	Release Valve	1
5	Ball Cup	2
6	Spring	1
7	Spring	1
8	Screw	2
9	Nylon Ring	1
10	Cylinder	1
11	O-Ring	1
12	Cup Seal	1
13	Ram	1
14	Packing	1
15	Reservoir	1
16	Filler Plug	1
17	Nylon Ring	1
18	Top Nut	1
19	O-Ring	1
20	Spring Plate	1
21	Spring	2
22	Eye Bolt	2
23	Nut	2
24	Lock Washer	2
25	Washer	1
26	Pump Cylinder	1
27	O-Ring	1
28	Nylon Ring	1

Part	Description	Qty
29	Back-up Ring	1
30	Piston	1
31	Pin	3
32	R-Pin	3
33	Connector	1
34	Handle Bracket	1
35	Lock Lever	1
36	Lever	1
37	Nut	1
38	O-Ring	1
39	O-Ring	1
40	Packing	1
41	Throttle	1
42	Spring	1
43	Nut	1
44	Air Hose Connector	1
45	Valve Body	1
46	Screw	1
47	Air Hose	1
48	Air Motor	1
49	Ball	1
50	Ball Cup	1
51	Spring	1
52	Screw	1
53	O-Ring	1
54	Screw	1
55	Plastic Cap	1
56	Handle	2

TROUBLESHOOTING

Problem	Cause	Solution
Jack will not lift	Release valve not tightly closed Overload condition Air supply inadequate	Ensure release valve tightly closed Remedy overload condition Ensure adequate air supply
Jack bleeds off after lift	Release valve not tightly closed Overload condition Hydraulic unit malfunction	Ensure release valve tightly closed Remedy overload condition Contact place of purchase
Jack will not lower after unloading	Reservoir overfilled Linkages binding	Drain fluid to proper level Clean and lubricate moving parts
Poor lift performance	Fluid level low Air trapped in system	Drain fluid to fluid level With ram fully retracted, remove oil filler plug to let pressurised air escape reinstall oil filler plug
Will not lift to full extension	Fluid level low	Ensure proper fluid level

WARRANTY

TradeQuip products have been carefully tested and inspected before shipment and are guaranteed to be free from defective materials and workmanship for a period of 12 months from the date of purchase except where tools are hired out when the guarantee period is ninety days from the date of purchase.

Should the machine develop any fault, please return the complete tool to your nearest authorised warranty repair agent or contact TQB Brands Pty Ltd Warranty team – warranty@tqbbrands.com.au.

If upon inspection it is found that the fault occurring is due to defective materials or workmanship, repairs will be carried out free of charge. This guarantee does not apply to normal wear and tear, nor does it cover any damage caused by misuse, careless or unsafe handling, alterations, accident, or repairs attempted or made by any personnel other than the authorised TQB Brands Pty Ltd repair agent.

This guarantee applies in lieu of any other guarantee expressed or implied and variations of its terms are not authorised.

Your TQB Brands Pty Ltd guarantee is not effective unless you can produce upon request a dated receipt or invoice to verify your proof of purchase within the 12 month period.

Consumer Guarantee

Our goods come with a guarantee that cannot be excluded under the Australian Consumer Law. You are entitled to a replacement or refund for a major failure and compensation for any other reasonably foreseeable loss or damage. You are also entitled to have the goods repaired or replaced if the goods fail to be of acceptable quality and the failure does not amount to a major failure.



All images and illustrations shown are for reference purposes only. All information, specifications and illustrations in this manual are based on the latest information available at the time of publication and are subject to change without notice. The information in this manual is periodically revised to ensure the latest information is included. Download the latest version of this manual and other related technical documentation from www.tqbbrands.com.au.