



TQB Brands Pty Ltd



Air/Hydraulic Press Pump Replacement Instructions

Product Codes: PROSHPR30TA/50TA

Follow the steps outlined below for the removal and replacement of the Press Pump on Product Codes: PROSHPR30TA & PROSHPR50TA Air/Hydraulic Press.

Press Pump Replacement Instructions

1. Open the release tap to the retract position and allow the ram assembly to fully retract leaving the release in the open position.



2. Open the Black plastic pump and reservoir covers at the top of the press upper head assembly.

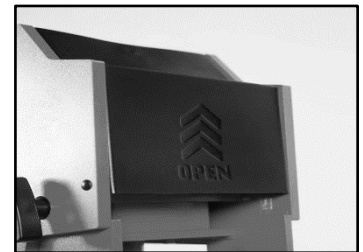

3. Once the pump, reservoir and ram are exposed, disconnect the air and hydraulic lines from the pump taking care to plug the lines or fittings to prevent oil loss.

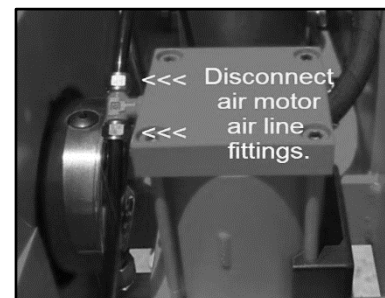
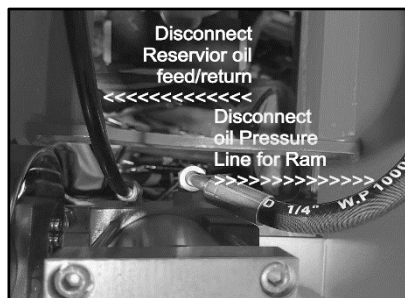

4. Pull the manual pump lever downwards until the pump piston travel pin holes align and insert a pin or wire to hold the pump piston during the next steps.

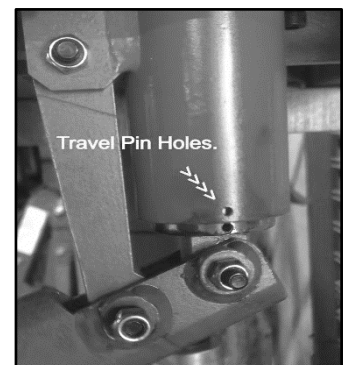

5. Remove the two manual pump linkage bolts from the lower section of the pump and remove the handle and linkage then put aside.

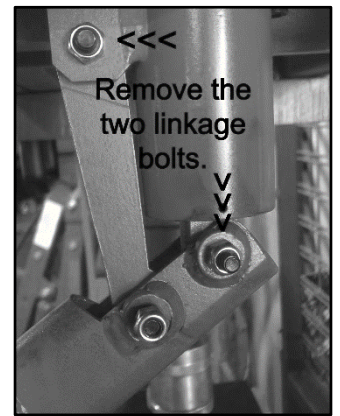

6. Remove the release knob assembly by tapping out the roll pin, then remove the four pump body mount screws to enable removal of the pump.

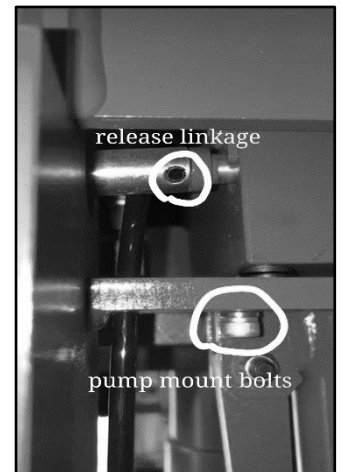

7. Once the pump is removed place it in an upright clamping device such as a mounted vice then remove the gauge adaptor and gauge assembly and place aside. Mount the new pump assembly and remove the gauge adaptor and replace with the old adaptor and gauge assembly, make sure you use the seal and backing rings from the new pump [items 22 & 23 in drawing photo insert].

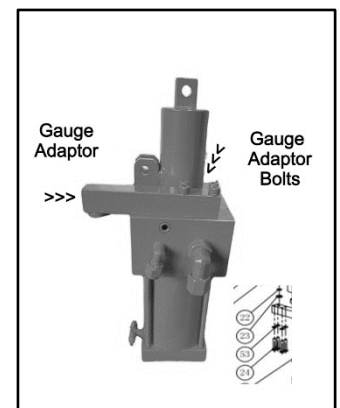

8. Reassemble the pump assembly back into the press frame in the reverse order from step 6 to step 2.
9. Follow the Bleed Procedure outlined below.

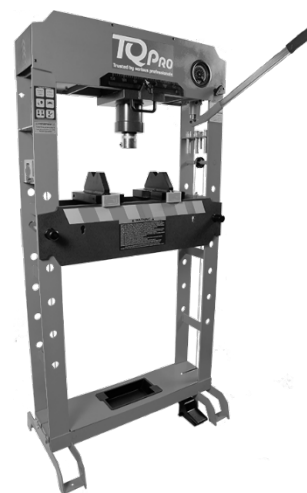
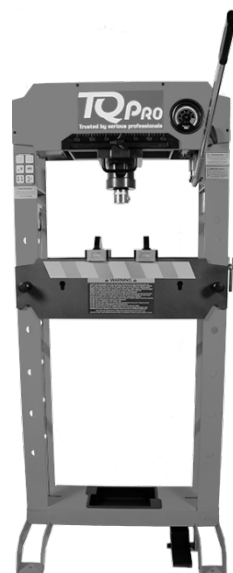

The usual symptoms of a single acting press ram with air in the Hydraulic system are as follow;

- No resistance in the pump stroke while pumping up a load [handle feels light]
- Most of the down stroke of the pump handle taken up but no advance or retract movement of the Ram
- Ram advances erratically while being pumped
- Air motor pump runs but no or limited movement in the Lift Ram

Filling Instructions

PROSHPR30TA & PROSHPR50TA

Remove the Filler and if required, refill with *32 Grade Hydraulic until the oil is within 3cm of the filler hole then Replace the Filler Bung.



Air & Manual Pumps Bleeding Instruction

Manual Pump: open the release valve by turning it counterclockwise. Pump several full strokes to eliminate any air in the system.



Air Pump: open the release valve by turning it counter clockwise. Connect the quick coupler-male into the air supply hose quick coupler-female, then turn on the air valve letting the pump work for several times to eliminate any air in the system.



Press Ram Bleeding Instructions

Manual Pump: Close the release valve and Insert the Pump Handle into the socket of manual pump and pump the handle until the ram is at full stroke then open the release and allow the ram to fully retract.

Air Pump: Close the release valve and depress the air pump pedal and pump until the ram is at full stroke then open the release and allow the ram to fully retract.

Should any of the symptoms described in the instruction's introduction, please repeat the bleeding processes 1 to 7 or alternatively contact your TQB Brands Distributor.

At this point both the Pump and Press Ram should be free of air and the Jack ready for operation

*The Borum/TQPro range of Presses use grade 32 Grade Hydraulic Oil for the correct operation and compatibility with the seals used in their construction.